

KATO

KR-500

Rough Terrain Crane

ROUGHTERR

SPECIFICATION



شرکت ایمن مرکزی آر (سهامی خاص) **KATO WORKS CO.,LTD.**

نماینده رسمی فروش و خدمات پس از فروش
جرثقیل های کاتو و هیلتاچی سومیتومو در ایران

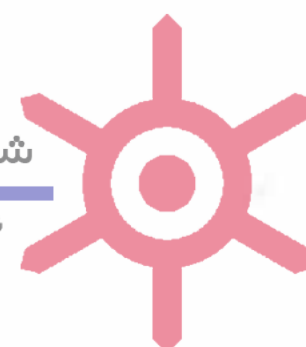

DIMENSIONS

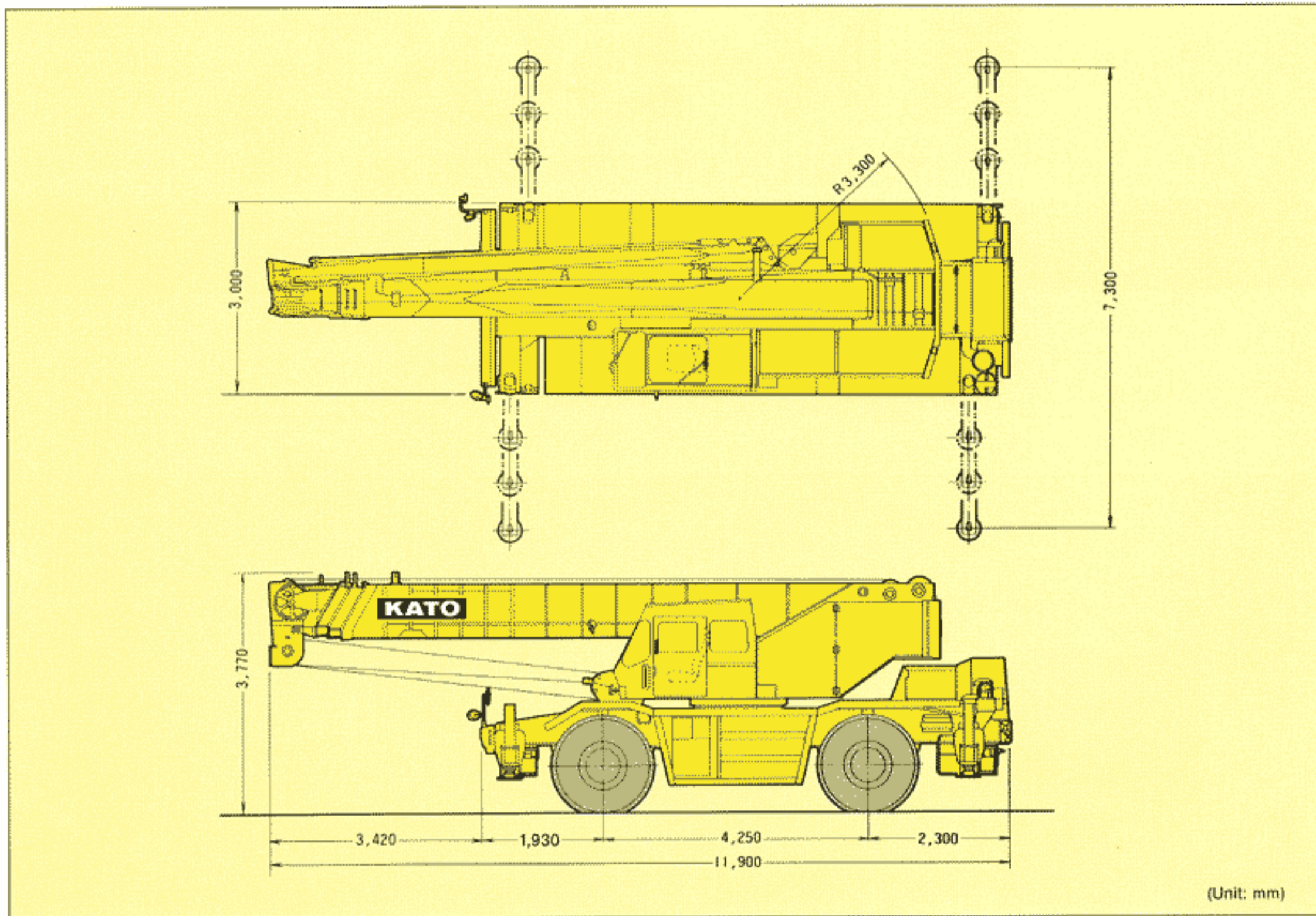

(Unit: mm)

CARRIER SPECIFICATIONS

Drive system	4 × 4
Maximum traveling speed	53 km/h
Gradeability (tan θ)	60 % (computed @G.V.W. = 37,000 kg)
Minimum turning radius (center of extreme outer tire)	6.2 m (4 wheel steer) 10.5 m (2 wheel steer)

● General dimensions

Overall length	approx. 11,900 mm
Overall width	approx. 3,000 mm
Overall height	approx. 3,770 mm
Wheel base	4,250 mm
Treads:	
Front	2,420 mm
Rear	2,420 mm
Center to center of extended outriggers	7,300 mm (Fully extended)
Gross vehicle weight	approx. 37,000 kg

● Engine

Maker	Mitsubishi
Model	6D22T (Turbo-charger)
Type	4 cycle, water cooled, diesel
No. of cylinder	6
Piston displacement	11,149 cc
Max. output horsepower	270 PS/2,200 r.p.m. 199 KW/2,200 r.p.m.
Max. output torque	105 kg-m/1,200 r.p.m. 1,029 N-m/1,200 r.p.m.

NOTE: The output is in accordance with JIS D1004, 1956. Rated power output guaranteed within 5% at standard ambient condition.

Torque converter	Engine mounted 3 elements 1 stage (with lock up clutch)
Transmission	Remote mounted full powershift with rear axle disconnect 6 forward & 6 reverse speed

Axle:	Front	Planetary drive/steer type
	Rear	Planetary drive/steer type, with no-spin differential
Suspension:	Front & Rear	Semi-elliptic leaf spring equipped with hydraulic shock absorbers and hydraulic locking device
Steering		Full hydraulic power steering with reverse steering correction mechanism Three steering modes available 1. Front wheel steer 2. 4-wheel coordinated steer 3. 4-wheel crab steer

● Brakes

Service brake	Air-over hydraulic disk brake on 4 wheels (2 circuits) Equipped with service brake lock
Parking brake	Spring applied, electrically air released cab-controlled parking brake mounted on front axle, internal expanding type
Electric system	24 V
Battery	12V – 120AH × 2
Fuel tank capacity	300 lit.
Driver's cab	All steel welded construction, 1 person (2 seats: optional)
Tire size:	
Front	18.00 - 25 - 28 PR(OR)
Rear	18.00 - 25 - 28 PR(OR)

NOTE: Spare tire is not mounted on the machine.

● Safety devices

	Emergency steering device Rear wheel steering lock Brake fluid leak warning device Suspension lock device Service brake lock Engine overrun alarm
--	--

اروند (سهامی خاص) نمایندگی فروش و خدمات پس از فروش جرثقیل های کاتو و هیلتاچی سومیتومو در ایران

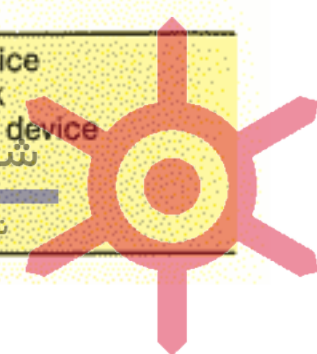

CRANE SPECIFICATIONS

Name	KATO ROUGHTER (ROUGH TERRAIN CRANE)
Model	KATO KR-500
• Performance	
Lifting capacity (360° arc. with outriggers fully extended)	50.0 tons × 3.0 m (9.20 m boom)
	28.0 tons × 4.0 m (15.35 m boom)
	18.0 tons × 5.5 m (21.50 m boom)
	13.0 tons × 7.0 m (27.65 m boom)
	7.5 tons × 9.0 m (33.80 m boom)
	4.0 tons × 14.0 m (9.2 m—33.8 m boom + rooster sheave)
	4.0 tons × 10.0 m (33.80 m boom + 8.1 m jib at 5° offset)
	3.0 tons × 11.5 m (33.80 m boom + 8.1 m jib at 17° offset)
	2.0 tons × 16.3 m (33.80 m boom + 8.1 m jib at 30° offset)
	2.5 tons × 11.0 m (33.80 m boom + 13.0 m jib at 5° offset)
	1.5 tons × 14.1 m (33.80 m boom + 13.0 m jib at 17° offset)
	1.0 ton × 18.4 m (33.80 m boom + 13.0 m jib at 30° offset)
	8.0 tons × 8.0 m (9.2 m boom + 14 m luffing jib)
	8.0 tons × 9.0 m (15.35 m boom + 14 m luffing jib)
	7.0 tons × 12.0 m (21.50 m boom + 14 m luffing jib)
	3.5 tons × 20.0 m (27.65 m boom + 14 m luffing jib)
	2.0 tons × 26.0 m (33.80 m boom + 14 m luffing jib)
	4.0 tons × 16.0 m (9.2 m boom + 19 m luffing jib)
	4.0 tons × 20.0 m (15.35 m boom + 19 m luffing jib)
	3.5 tons × 20.0 m (21.50 m boom + 19 m luffing jib)
1.8 tons × 30.0 m (27.65 m boom + 19 m luffing jib)	
1.0 ton × 36.0 m (33.80 m boom + 19 m luffing jib)	

Boom length	9.2 m ~ 33.8 m (5 sections)
Boom derricking angle	0° ~ 82°
Boom derricking time	46 sec. (0° ~ 82°)
Boom extending time	102 sec. (9.2 m ~ 33.8 m)
Hoisting line speed	
Main winch	120 m/min. (at 3rd layer)
Auxiliary winch	110 m/min. (at 2nd layer)
Hoisting hook speed	
Main winch	10.0 m/min. (at 3rd layer)
Auxiliary winch	110 m/min. (at 2nd layer)
(parts of line: 12)	
(parts of line: 1)	
Slewing speed	2.9 r.p.m.
Wire rope for hoisting	
Main winch:	
Type	U4 × SeS (39) (Non-rotating type)
Diameter	18 mm
Length	190 m
Auxiliary winch:	
Type	U4 × SeS (39) (Non-rotating type)
Diameter	18 mm
Length	160 m
Hydraulic system	
Oil pump	4 pumps, gear and axial plunger type
Hoisting motor	Axial plunger type
Slewing motor	Axial plunger type
Cylinder	Double acting type
Control valve	4 way double acting with integral check and relief valves
Oil reservoir capacity	560 lit.
Winch system	
Main winch	Driven by axial plunger type hoisting motor through built-in gear reduction.
Auxiliary winch	Controlled independently by respective operating lever.
	Equipped with automatic brake.

• Safety devices

ACS (Automatic Crane Stopper)
(Digital display of seven factors: Safety level, boom angle, working radius, boom length, critical load, actual load, maximum hook lift)
Boom falling prevention device
Overhoist prevention device
Drum lock device
Automatic winch brake
Irregular winding prevention device
Hydraulic safety valve
Outrigger lock device
Slewing lock device

NOTE: Various speeds above mentioned are subject to no load.

• Options

- Fly jib
- Luffing jib
- Auxiliary winch drum
- Auxiliary winch motor
- Wire rope and hook for auxiliary hoist
- Rooster sheave
- Voice alarm device for ACS moment limiter
- Heater
- Defroster

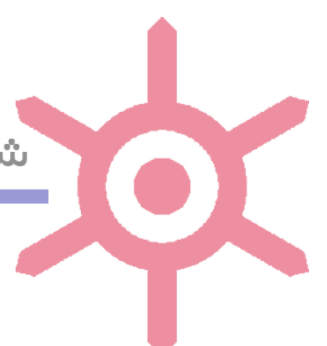

MAIN BOOM

WORKING RANGE

(Operation with Boom and Fly jib)

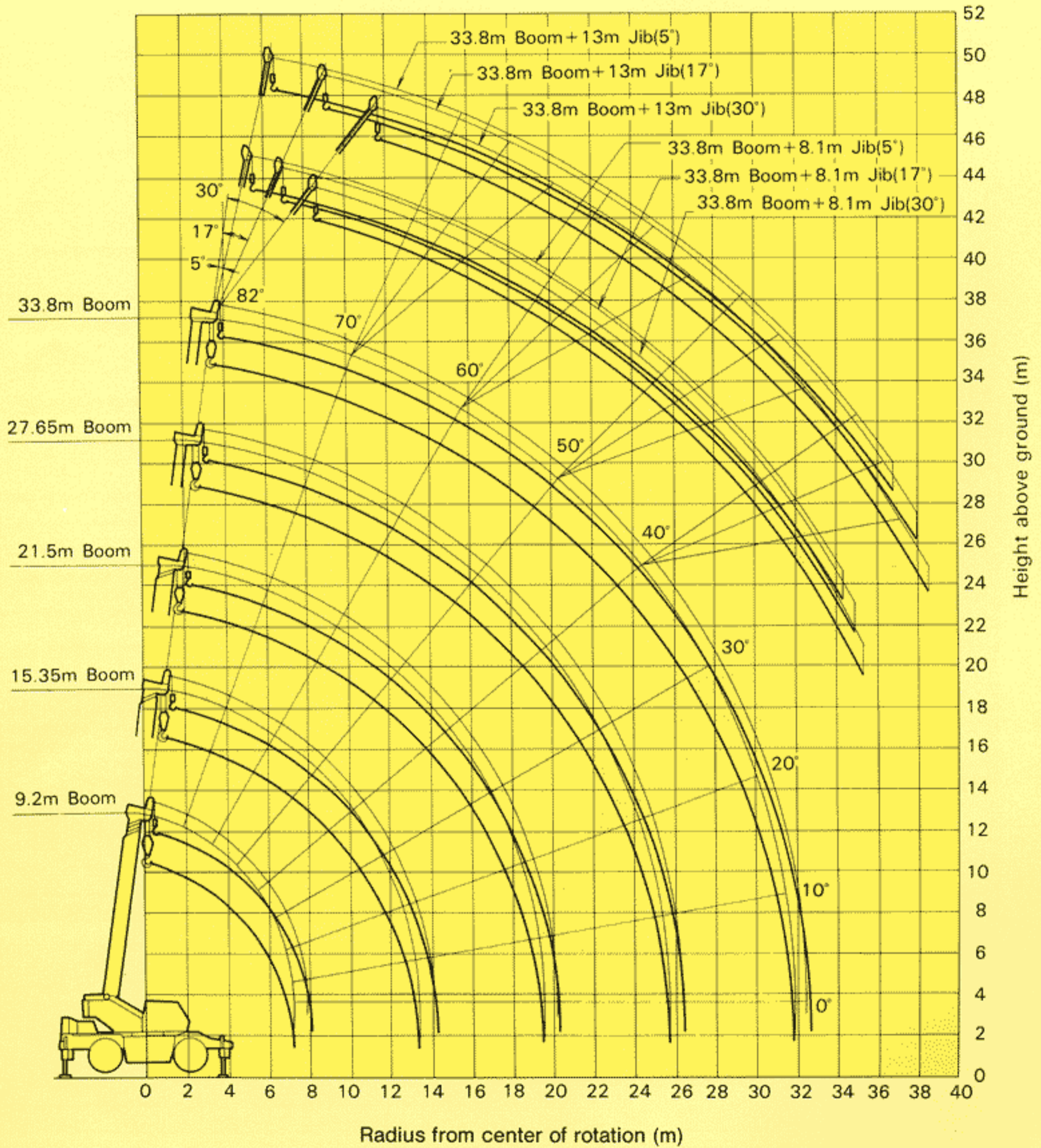

Note: Deflection of Boom and Fly Jib excluded.

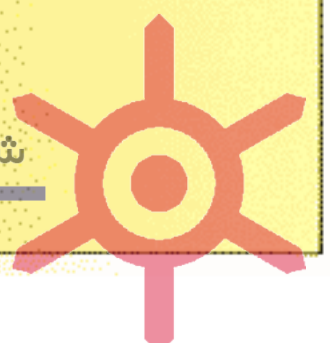



• 9.2 m ~ 33.8 m Boom

RATED LIFTING CAPACITY

Based on 75% of tipping loads



Working radius (m)	On outriggers									
	Outriggers fully extended					Outriggers intermittently extended (5.5m)				
	360° full range					Over side				
	9.2m Boom	15.35m Boom	21.5m Boom	27.65m Boom	33.8m Boom	9.2m Boom	15.35m Boom	21.5m Boom	27.65m Boom	33.8m Boom
3.0	50.00	28.00	18.00			50.00	28.00	18.00		
3.5	39.80	28.00	18.00			39.80	28.00	18.00		
4.0	35.60	28.00	18.00	13.00		35.60	28.00	18.00	13.00	
4.5	32.10	25.30	18.00	13.00	7.50	32.10	25.30	18.00	13.00	7.50
5.0	29.20	23.10	18.00	13.00	7.50	29.20	23.10	18.00	13.00	7.50
5.5	26.60	21.20	18.00	13.00	7.50	24.00	21.20	18.00	13.00	7.50
6.0	23.90	19.60	16.60	13.00	7.50	20.40	18.40	16.60	13.00	7.50
6.5	21.40	18.30	15.45	13.00	7.50	17.45	16.00	15.46	13.00	7.50
7.0	19.00	17.10	14.40	13.00	7.50	14.80	13.90	13.60	13.00	7.50
7.5		16.00	13.50	12.20	7.50		12.20	12.05	12.20	7.50
8.0		15.00	12.70	11.50	7.50		10.90	10.75	11.50	7.50
9.0		12.10	11.30	10.30	7.50		8.80	8.65	9.30	7.50
10.0		10.00	9.60	9.35	6.80		7.15	7.05	7.60	6.80
11.0		8.40	8.10	8.50	6.25		5.90	5.80	6.40	6.25
12.0		7.15	6.90	7.35	5.75		5.00	4.85	5.45	5.75
13.0		6.20	5.90	6.40	5.30		4.20	4.05	4.65	4.95
14.0			5.10	5.60	4.90			3.40	4.00	4.30
16.0			3.90	4.40	4.25			2.40	2.95	3.25
18.0			2.95	3.45	3.70			1.60	2.15	2.50
19.0			2.60	3.10	3.35			1.30	1.80	2.20
20.0				2.75	3.00				1.50	1.90
22.0				2.20	2.40				1.10	1.40
24.0				1.70	1.95				0.75	1.00
25.0				1.50	1.75					0.85
26.0					1.60					0.70
28.0					1.30					
30.0					1.10					
31.0					1.00					
Critical boom angle	—	—	—	—	—	—	—	—	—	33°

(Unit: Metric ton)

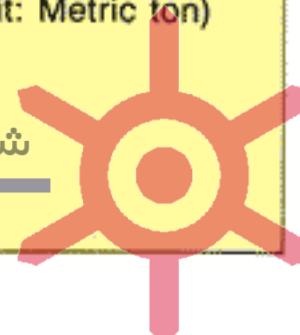



• 9.2~33.8 m Boom



• 33.8m Boom + 8.1 m Jib



• 33.8 m Boom + 13.0 m Jib

RATED LIFTING CAPACITY

Based on 75% of tipping loads



Working radius (m)	On outriggers								
	Outriggers intermittently extended (4.0m)					Outriggers retracted (blocked on vertical cylinders)			
	Over side					Over side			
	9.2m Boom	15.35m Boom	21.5m Boom	27.65m Boom	33.8m Boom	9.2m Boom	15.35m Boom	21.5m Boom	
30	4000	2800	1800			1500	1100	1100	
35	3100	2800	1800			1500	1100	1100	
40	2450	2260	1800	1300		1200	1100	1100	
45	1930	1860	1800	1300	750	980	930	920	
50	1600	1530	1490	1300	750	820	780	765	
55	1330	1300	1240	1300	750	700	660	640	
60	1140	1100	1060	1130	750	600	560	540	
65	990	950	920	975	750	520	480	460	
70	860	830	800	860	750	440	410	395	
75		730	700	780	750		350	340	
80		640	620	680	690		305	290	
90		510	490	545	575		225	205	
100		410	390	445	475		155	135	
110		330	310	370	400		100		
120		270	250	305	335				
130		220	195	250	280				
140			150	200	240				
160			080	130	165				
180				080	110				
190					085				
Critical boom angle	—	—	30°	42°	51°	—	30°	55°	

(Unit: Metric ton)

RATED LIFTING CAPACITY

Based on 75% of tipping loads





Boom angle (°)	33.8 m Boom + 8.1 m Jib					
	Outriggers fully extended					
	360° full range					
	offset 5°		offset 17°		offset 30°	
	Working radius (m)	Load	Working radius (m)	Load	Working radius (m)	Load
82.0	73	400	8.7	300	10.2	200
78.0	100	400	11.5	300	13.0	200
75.0	12.2	340	13.5	265	15.0	200
73.0	135	310	15.0	245	16.3	200
70.0	15.7	270	16.8	225	18.1	185
65.0	190	225	20.1	190	21.3	160
60.0	22.1	190	23.4	165	24.1	145
55.0	25.1	165	26.3	150	26.9	130
52.0	26.7	155	27.9	145	28.3	125
50.0	27.7	140	28.9	130	29.3	120
48.0	28.7	125	29.8	118	30.3	115
45.0	30.2	105	31.1	100	31.6	095
40.0	32.3	080	33.1	075	33.5	070
35.0	34.3	060	34.9	055	35.3	050
Critical boom angle	30°		30°		30°	

(Unit: Metric ton)

Boom angle (°)	33.8 m Boom + 8.1 m Jib					
	Outriggers intermittently extended (5.5m)					
	Over side					
	offset 5°		offset 17°		offset 30°	
	Working radius (m)	Load	Working radius (m)	Load	Working radius (m)	Load
82.0	73	400	8.7	300	10.2	200
78.0	100	400	11.5	300	13.0	200
75.0	12.2	340	13.5	265	15.0	200
73.0	135	310	15.0	245	16.3	200
70.0	15.7	270	16.8	225	18.1	185
65.0	190	225	20.1	190	21.3	160
62.0	20.7	180	21.9	155	23.0	150
60.0	21.9	155	23.1	135	24.1	130
55.0	24.8	100	26.0	090	26.8	085
50.0	27.4	060	28.5	055	29.1	050
Critical boom angle	45°		45°		45°	

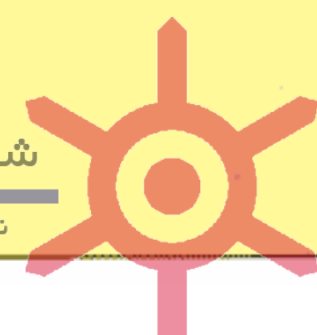
(Unit: Metric ton)





338 m Boom + 8.1 m Jib						
Outriggers intermittently extended (4.0m)						
Boom angle (°)	Over side					
	offset 5°		offset 17°		offset 30°	
	Working radius (m)	Load	Working radius (m)	Load	Working radius (m)	Load
82.0	73	4.00	8.7	3.00	10.2	2.00
78.0	10.0	4.00	11.5	3.00	13.0	2.00
75.0	12.2	3.40	13.5	2.65	15.0	2.00
73.0	13.4	2.85	15.0	2.45	16.3	2.00
72.0	14.0	2.60	15.5	2.25	16.8	1.90
70.0	15.3	2.10	16.6	1.90	18.0	1.65
65.0	18.4	1.20	19.8	1.05	20.9	1.00
60.0	21.6	0.60	22.6	0.55	23.6	0.50
Critical boom angle	57°		57°		57°	

(Unit: Metric ton)



338 m Boom + 13.0 m Jib						
Outriggers intermittently extended (5.5m)						
Boom angle (°)	Over side					
	offset 5°		offset 17°		offset 30°	
	Working radius (m)	Load	Working radius (m)	Load	Working radius (m)	Load
82.0	8.7	2.50	11.0	1.50	13.0	1.00
79.0	11.0	2.50	13.4	1.50	15.4	1.00
78.0	11.9	2.35	14.1	1.50	16.2	1.00
75.0	14.2	2.05	16.3	1.40	18.4	1.00
70.0	18.0	1.65	20.2	1.20	22.2	0.90
65.0	21.9	1.35	23.8	1.03	25.5	0.83
60.0	25.4	1.15	27.3	0.90	28.5	0.78
55.0	28.4	0.80	30.0	0.70	31.3	0.65
Critical boom angle	50°		50°		50°	

(Unit: Metric ton)



338 m Boom + 13.0 m Jib						
Outriggers fully extended						
Boom angle (°)	360° full range					
	offset 5°		offset 17°		offset 30°	
	Working radius (m)	Load	Working radius (m)	Load	Working radius (m)	Load
82.0	8.7	2.50	11.0	1.50	13.0	1.00
79.0	11.0	2.50	13.4	1.50	15.4	1.00
78.0	11.9	2.35	14.1	1.50	16.2	1.00
75.0	14.2	2.05	16.3	1.40	18.4	1.00
70.0	18.0	1.65	20.2	1.20	22.2	0.90
65.0	21.9	1.35	23.8	1.03	25.5	0.83
60.0	25.4	1.15	27.3	0.90	28.5	0.78
55.0	28.6	1.00	30.3	0.82	31.5	0.73
50.0	31.7	0.85	33.2	0.75	34.0	0.70
45.0	34.4	0.75	35.7	0.70	36.4	0.56
40.0	36.8	0.65	37.9	0.60	38.5	0.55
Critical boom angle	35°		35°		35°	

(Unit: Metric ton)



338 m Boom + 13.0 m Jib						
Outriggers intermittently extended (4.0m)						
Boom angle (°)	Over side					
	offset 5°		offset 17°		offset 30°	
	Working radius (m)	Load	Working radius (m)	Load	Working radius (m)	Load
82.0	8.7	2.50	11.0	1.50	13.0	1.00
79.0	11.0	2.50	13.4	1.50	15.4	1.00
78.0	11.9	2.35	14.1	1.50	16.2	1.00
75.0	14.2	2.05	16.3	1.40	18.4	1.00
70.0	18.0	1.65	20.2	1.20	22.2	0.90
68.0	19.4	1.30	21.5	1.15	23.6	0.85
65.0	21.5	0.90	23.5	0.80	25.2	0.75
60.0	24.5	0.50				
Critical boom angle	58°		58°		58°	

(Unit: Metric ton)

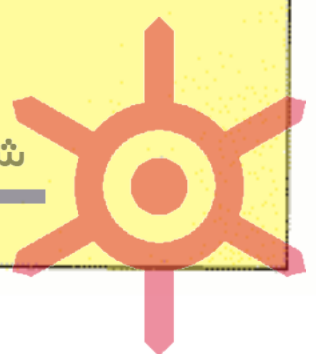

NOTE:**— ON OUTRIGGERS —**

- 1.) The rated lifting capacities are the maximum load guaranteed on a firm level ground and include the weight of hook block and other lifting equipment. The capacities enclosed with bold line are based on the structural strength of machine and the others are based on the stability of machine.

Hook	for 50 ton	for 20 ton	for 4 ton
Weight (kg)	500	270	120

- 2.) The working radii as given in the table are the actual values including the deflection of the boom. Therefore, operate the machine based on the working radius. However, the working radii shown for jib operations are based on the values obtained when the boom is fully extended (33.8 m).
Jib operations should be performed on the basis of boom angle only, regardless of boom length when the boom is not fully extended.
- 3.) Critical boom angles for each boom length are shown on bottom-most line of lifting capacity table.
If the boom angle is lowered to less than the critical boom angle, the machine will tip over without load. Therefore, never lower the boom below these angles.
- 4.) If the boom length exceeds the specified value, the rated lifting capacities for the boom length above and below the present boom length should be referred to, and the crane should be operated within the smaller lifting capacity.
- 5.) Lifting capacities over side vary with outrigger width extended. Operation must be carried out according to the lifting capacity table based on the corresponding outrigger width.
Lifting capacities over front/rear are equal to those with outriggers fully extended.
- 6.) When using the main boom with the jib installed, 1800 kg plus the weight of hook block and other lifting equipment, etc., should be subtracted from the rated lifting capacities. When performing the above operation, do not use the rooster sheave.

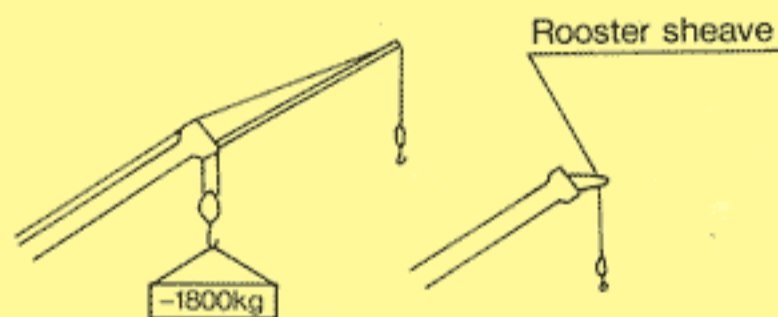

- 7.) The standard number of parts of line is shown in the table below. When the standard number of parts of line is not used, the minimum number of parts of line is determined so that weight per part will not exceed 4000 kg.

Boom length	9.2	9.2m ~ 15.35m	15.35m ~ 21.5m	21.5m ~ 33.8m	Jib, Rooster sheave
Parts of line	12	7	5	4	1

- 8.) The rated lifting capacities for the rooster sheave are equivalent to the rated lifting capacities for the main boom to a maximum of 4000 kg.
At all times the weight of all lifting equipment in use (including main hook block suspended from boom head) forms part of load and must be subtracted from the rated lifting capacity.
- 9.) Free fall is adopted in principle to lower the hook only. If it is necessary to lower a load by free fall, its weight should be less than 20% of the rated lifting capacity and abrupt braking should not be allowed.
- 10.) The machine will tip over or be damaged if operated with a load exceeding that specified in the rated lifting capacity table or not conforming to correct handling.
If such trouble occurs, the machine will not be warranted.

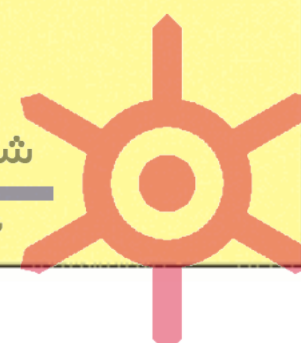



• 9.2 m~21.5 m Boom

RATED LIFTING CAPACITY

Based on 75% of tipping loads



Working radius (m)	STATIONARY ON RUBBER					
	9.2 m Boom		15.35 m Boom		21.5 m Boom	
	over front	360° full range	over front	360° full range	over front	360° full range
3.0	20.00	12.50	15.00	10.00		
3.5	20.00	10.90	15.00	10.00	11.00	5.50
4.0	17.70	9.30	15.00	8.60	11.00	5.50
4.5	16.00	7.80	15.00	7.20	11.00	5.50
5.0	14.60	6.50	14.00	6.00	11.00	5.50
5.5	13.35	5.45	13.00	5.00	11.00	4.80
6.0	12.20	4.65	12.00	4.25	10.15	4.15
6.5	11.15	4.00	11.00	3.60	9.30	3.50
7.0	10.20	3.40	10.00	3.10	8.55	3.00
8.0			7.90	2.30	7.20	2.20
9.0			6.40	1.65	6.05	1.55
10.0			5.20	1.15	5.00	1.10
11.0			4.30		4.10	
12.0			3.60		3.45	
13.0			3.00		2.85	
14.0					2.40	
15.0					1.95	
16.0					1.60	
17.0					1.30	
18.0					1.00	
Critical boom angle	—	—	—	35°	—	56°

(Unit: Metric ton)



Working radius (m)	PICK & CARRY (Max. 2 km/h)					
	9.2 m Boom		15.35 m Boom		21.5 m Boom	
	over front	360° full range	over front	360° full range	over front	360° full range
3.0	14.50	8.00	10.50	6.50		
3.5	14.50	8.00	10.50	6.50	8.00	4.50
4.0	13.00	7.00	10.50	6.50	8.00	4.50
4.5	11.75	6.00	10.50	5.60	8.00	4.50
5.0	10.65	5.15	10.50	4.85	8.00	4.50
5.5	9.65	4.40	9.50	4.15	8.00	3.95
6.0	8.80	3.80	8.70	3.55	8.00	3.50
6.5	8.10	3.20	8.00	3.00	7.45	3.00
7.0	7.50	2.70	7.30	2.55	6.90	2.55
8.0			6.10	1.90	5.80	1.85
9.0			5.15	1.35	4.80	1.30
10.0			4.30	0.90	4.00	0.85
11.0			3.60		3.30	
12.0			3.00		2.70	
13.0			2.40		2.25	
14.0					1.90	
15.0					1.60	
16.0					1.30	
17.0					1.00	
18.0					0.80	
Critical boom angle	—	—	—	37°	20°	57°

(Unit: Metric ton)

NOTE:

— ON RUBBER —

- The rated lifting capacities are the load guaranteed when the ground surface is good, specified tire pressure is maintained and spring lock cylinder are fully retracted.
Specified tire pressure: 6.75 kg/cm²
- Rated lifting capacities in front area (2° arc) are different from those for full working area (360° arc).
Great care should be taken when transferring from over front to over side since there is a danger of overloading

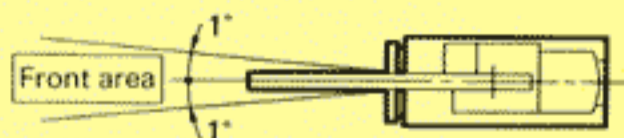

- For "On Rubber" lifting, boom operation with 21.5 m boom length and more, jib operation and free fall operation are not permitted.
- Apply the parking brake while crane is operating stationary on rubber.
- Push the Hi-Lo switch before Pick & Carry operation to insure low range speed.
- In Pick & Carry operation, move less than 2 km/h and keep the lifting load close to the ground.
Especially avoid abrupt steering, accelerating and braking so as to swing the lifting load.
- Do not operate crane functions while carrying the load.
- Besides these cautions as shown above, conform to items 1, 2, 3, 4, 7, 8, 9 and 10 of cautions for "ON OUTRIGGERS".

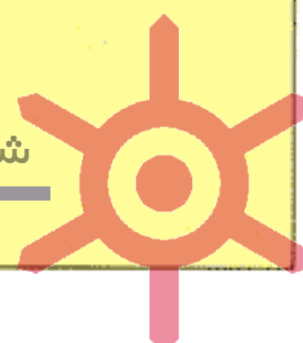

LUFFING JIB

WORKING RANGE

(Operation with Boom and Luffing jib)

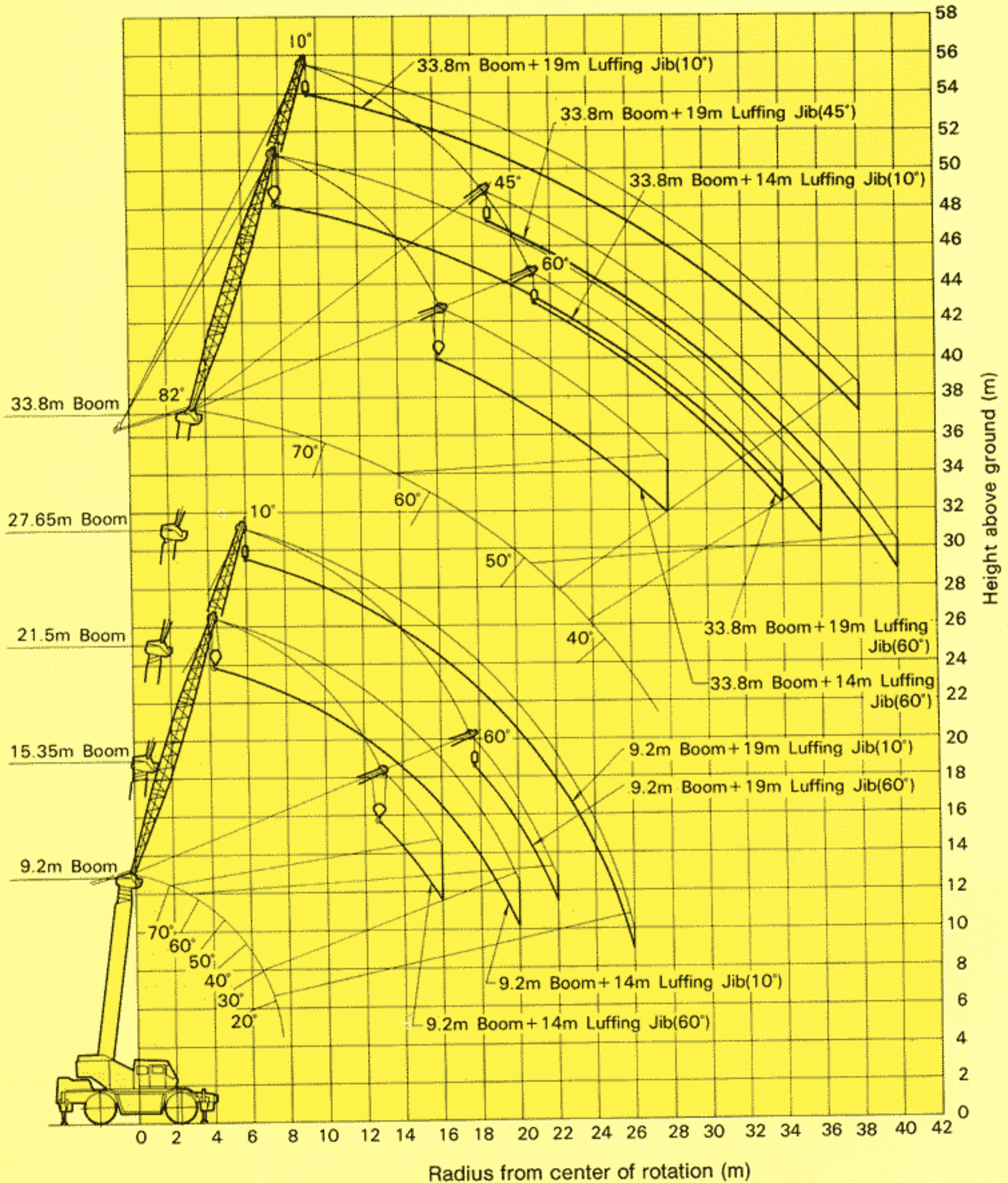

Note: Deflection of Boom and Fly Jib excluded.

شرکت ایمن مرکزی اروند (سهامی خاص)

نمایندگی رسمی فروش و خدمات پس از فروش
جرثقیل های کاتو و هیلتاچی سومیتومو در ایران

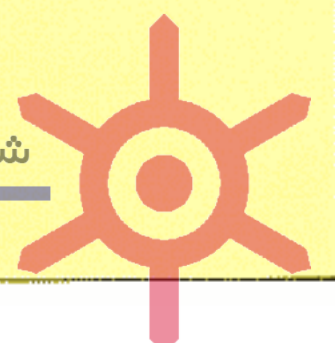



• 14 m Luffing Jib

RATED LIFTING CAPACITY

Based on 75% of tipping loads

14 m Luffing jib



Working radius (m)	Outriggers fully extended 360° full range																				Working radius (m)								
	9.2 m Boom				15.35 m Boom				21.5 m Boom				27.65 m Boom				33.8 m Boom Working												
	Offset angle				Offset angle				Offset angle				Offset angle				Offset angle												
	10°	30°	45°	60°	10°	30°	45°	60°	10°	30°	45°	60°	10°	30°	45°	60°	10°	30°	45°	60°	10°	30°	45°	60°					
6.0	8.00				8.00																			6.0					
8.0	8.00				8.00				7.00								3.50								8.0				
9.0	7.15				8.00				7.00								3.50					2.00			9.0				
10.0	6.45	4.30			7.90				7.00								3.50					2.00			10.0				
12.0	5.40	4.30			6.65	4.30			7.00	4.30							3.50	3.50				2.00	2.00		12.0				
14.0	4.60	3.80	3.40		5.75	4.30	3.40		6.50	4.30	3.40						3.50	3.50				2.00	2.00		14.0				
16.0	4.05	3.50	3.20	3.00	5.05	4.00	3.40	3.00	5.20	4.30	3.40	3.00					3.50	3.50	3.20			2.00	2.00		16.0				
18.0	3.60	3.25	3.00		4.50	3.65	3.25	3.00	4.20	4.00	3.40	3.00					3.50	3.50	3.20	3.00		2.00	2.00	2.00	1.80	18.0			
20.0	3.25	3.05			3.70	3.40	3.10	3.00	3.35	3.75	3.30	3.00					3.50	3.50	3.20	3.00		2.00	2.00	2.00	1.80	20.0			
22.0					3.10	3.20	2.90		2.70	3.05	3.20	3.00					2.80	3.10	3.20	3.00		2.00	2.00	2.00	1.80	22.0			
24.0					2.55	2.70			2.15	2.40	2.60						2.30	2.55	2.70	2.80		1.80	2.00	2.00	1.80	24.0			
26.0					2.10				1.70	1.90	2.05						1.85	2.10	2.20	2.30		1.60	1.80	2.00	1.80	26.0			
28.0									1.35	1.50							1.50	1.75	1.80			1.40	1.60	1.80	1.80	28.0			
30.0									1.05	1.20							1.15	1.40	1.45			1.20	1.40	1.50		30.0			
32.0									0.80								0.85	1.10	1.10			0.95	1.20	1.20		32.0			
34.0																	0.60	0.80				0.70	0.90	0.95		34.0			
36.0																		0.50				0.45	0.60	0.70		36.0			
Critical boom angle	10°	30°	45°	60°	10°	30°	45°	60°	10°	30°	45°	60°	10°	30°	45°	60°	10°	30°	45°	60°	38°	40°	45°	60°					Critical boom angle

(Unit: Metric ton)

14 m Luffing jib



Working radius (m)	Outriggers Intermittently extended (5.5 m)																Over side				Working radius (m)								
	9.2 m Boom				15.35 m Boom				21.5 m Boom				27.65 m Boom				33.8 m Boom Working												
	Offset angle				Offset angle				Offset angle				Offset angle				Offset angle												
	10°	30°	45°	60°	10°	30°	45°	60°	10°	30°	45°	60°	10°	30°	45°	60°	10°	30°	45°	60°	10°	30°	45°	60°					
6.0	8.00				8.00																				6.0				
8.0	8.00				8.00				7.00								3.50									8.0			
10.0	6.45	4.30			7.90				7.00								3.50					2.00				10.0			
12.0	5.40	4.30			6.65	4.30			6.50	4.30							3.50	3.50				2.00	2.00			12.0			
14.0	4.60	3.80	3.40		5.30	4.30	3.40		4.90	4.30	3.40						3.50	3.50				2.00	2.00			14.0			
16.0	4.05	3.50	3.20	3.00	4.15	4.00	3.40	3.00	3.75	4.30	3.40	3.00					3.50	3.50	3.20			2.00	2.00			16.0			
18.0	3.60	3.25	3.00		3.30	3.65	3.25	3.00	2.90	3.40	3.40	3.00					2.90	3.50	3.20	3.00		2.00	2.00	2.00	1.80	18.0			
20.0	3.25	3.05			2.65	3.00	3.10	3.00	2.20	2.65	2.90	3.00					2.20	2.90	3.00	3.00		2.00	2.00	2.00	1.80	20.0			
22.0					2.10	2.40	2.50		1.60	2.00	2.30	2.40					1.60	2.20	2.40	2.50		1.65	2.00	2.00	1.80	22.0			
24.0					1.60	1.85			1.10	1.45	1.70						1.15	1.60	1.80	1.90		1.20	1.65	1.90	1.80	24.0			
26.0					1.20				0.70	1.00	1.10						0.75	1.10	1.30	1.40		0.80	1.20	1.40	1.50	26.0			
28.0										0.60								0.75	0.90			0.50	0.80	1.00	1.05	28.0			
30.0																		0.50				0.50	0.60			30.0			
Critical boom angle	10°	30°	45°	60°	10°	30°	45°	60°	35°	35°	45°	60°	45°	45°	45°	60°	45°	45°	45°	60°	52°	53°	55°	60°					Critical boom angle

(Unit: Metric ton)

14 m Luffing jib



Working radius (m)	Outriggers fully extended (4.0 m)																Over side				Working radius (m)						
	9.2 m Boom				15.35 m Boom				21.5 m Boom				27.65 m Boom				33.8 m Boom Working										
	Offset angle				Offset angle				Offset angle				Offset angle				Offset angle										
	10°	30°	45°	60°	10°	30°	45°	60°	10°	30°	45°	60°	10°	30°	45°	60°	10°	30°	45°	60°	10°	30°	45°	60°			
6.0	8.00				8.00																					6.0	
8.0	8.00				8.00				7.00								3.50										8.0
10.0	6.45	4.30			5.75				5.20								3.50					2.00					10.0
12.0	4.90	4.30			4.20	4.30			3.85	4.30							3.50	3.50				2.00	2.00			12.0	
14.0	3.80	3.80	3.40		3.20	3.80	3.40		2.80	3.40	3.40						2.80	3.40				2.00	2.00			14.0	
16.0	3.05	3.30	3.20	3.00	2.40	2.90	3.20	3.00	2.00	2.60	3.00	3.00					2.05	2.65	3.00			2.00	2.00			16.0	
18.0	2.45	2.65	2.75		1.80	2.20	2.40	2.60	1.30	1.90	2.20	2.45					1.40	2.00	2.30	2.50		1.40	1.90	2.00	1.80	18.0	
20.0	2.00	2.10			1.30	1.65	1.80	1.95	0.75	1.30	1.60	1.80					0.85	1.40	1.70	1.90		0.90	1.40	1.70	1.80	20.0	
22.0					0.90	1.20	1.35			0.80	1.10	1.20					0.90	1.20	1.35			0.95	1.20	1.40		22.0	
24.0						0.75												0.70	0.85				0.80	0.95		24.0	
Critical boom angle	10°	30°	45°	60°	10°	30°	45°	60°	53°	55°	55°	60°	60°	62°	62°	65°	62°	62°	65°	62°	64°	64°	65°	65°			Critical boom angle

(Unit: Metric ton)

رسمی فروش و خدمات پس از فروش

جرقیل های کاتو و هیتاچی سومیتومو در ایران

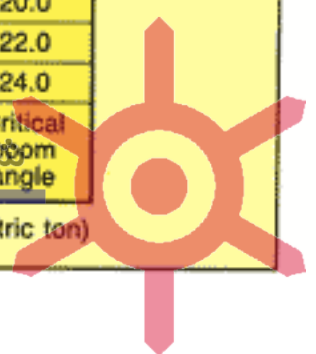



• 19 m Luffing Jib

RATED LIFTING CAPACITY

Based on 75% of tipping loads

19 m Luffing jib



Working radius (m)	Outriggers fully extended 360° full range																Working radius (m)								
	9.2 m Boom				15.35 m Boom				21.5 m Boom				27.65 m Boom					33.8 m Boom Working							
	Offset angle				Offset angle				Offset angle				Offset angle					Offset angle							
	10°	30°	45°	60°	10°	30°	45°	60°	10°	30°	45°	60°	10°	30°	45°	60°	10°	30°	45°	60°	10°	30°	45°	60°	
8.0	4.00				4.00				3.50																8.0
10.0	4.00				4.00				3.50								1.80								10.0
12.0	4.00				4.00				3.50								1.80				1.00				12.0
14.0	4.00	3.50			4.00	3.10			3.50	3.50							1.80				1.00				14.0
16.0	4.00	3.50	2.50		4.00	3.10			3.50	3.50							1.80	1.80			1.00				16.0
18.0	3.65	3.10	2.50		4.00	3.10	2.60		3.50	3.50	2.60						1.80	1.80			1.00	1.00			18.0
20.0	3.25	2.80	2.50	2.30	4.00	3.10	2.60	2.30	3.50	3.50	2.60	2.30	1.80	1.80	1.80		1.80	1.80	1.80	1.80	1.00	1.00	1.00	1.00	20.0
22.0	2.90	2.55	2.40	2.30	3.45	2.90	2.60	2.30	3.00	3.20	2.60	2.30	1.80	1.80	1.80	1.80	1.80	1.80	1.80	1.80	1.00	1.00	1.00	1.00	22.0
24.0	2.60	2.35	2.30		2.95	2.70	2.45	2.30	2.50	3.00	2.60	2.30	1.80	1.80	1.80	1.80	1.80	1.80	1.80	1.80	1.00	1.00	1.00	1.00	24.0
26.0	2.35				2.50	2.55	2.30		2.10	2.50	2.50	2.30	1.80	1.80	1.80	1.80	1.80	1.80	1.80	1.80	1.00	1.00	1.00	1.00	26.0
28.0					2.05	2.15	2.20		1.75	2.05	2.10	2.30	1.80	1.80	1.80	1.80	1.80	1.80	1.80	1.80	1.00	1.00	1.00	1.00	28.0
30.0					1.65	1.80			1.45	1.70	1.70		1.50	1.80	1.80	1.80	1.80	1.80	1.80	1.80	1.00	1.00	1.00	1.00	30.0
32.0					1.30				1.15	1.35	1.40		1.20	1.45	1.60		1.20	1.45	1.60	1.60	0.90	1.00	1.00	1.00	32.0
34.0									0.90	1.05			0.95	1.15	1.30		0.95	1.15	1.30	1.30	0.85	1.00	1.00	1.00	34.0
36.0									0.65	0.75			0.70	0.90	1.00		0.70	0.90	1.00	1.00	0.65	0.90	1.00		36.0
38.0													0.50	0.65			0.50	0.65			0.50	0.70	0.80		38.0
40.0																						0.50	0.60		40.0
Critical boom angle	10°	30°	45°	60°	10°	30°	45°	60°	10°	30°	45°	60°	32°	40°	45°	60°	42°	45°	45°	60°					Critical boom angle

(Unit: Metric ton)

19 m Luffing jib



Working radius (m)	Outriggers Intermittently extended (5.5 m) Over side																Working radius (m)								
	9.2 m Boom				15.35 m Boom				21.5 m Boom				27.65 m Boom					33.8 m Boom Working							
	Offset angle				Offset angle				Offset angle				Offset angle					Offset angle							
	10°	30°	45°	60°	10°	30°	45°	60°	10°	30°	45°	60°	10°	30°	45°	60°	10°	30°	45°	60°	10°	30°	45°	60°	
8.0	4.00				4.00				3.50																8.0
10.0	4.00				4.00				3.50								1.80								10.0
12.0	4.00				4.00				3.50								1.80				1.00				12.0
14.0	4.00	3.50			4.00	3.10			3.50	3.50							1.80				1.00				14.0
16.0	4.00	3.50	2.50		4.00	3.10			3.50	3.50							1.80	1.80			1.00				16.0
18.0	3.65	3.10	2.50		3.70	3.10	2.60		3.20	3.50	2.60						1.80	1.80			1.00	1.00			18.0
20.0	3.25	2.80	2.50	2.30	3.00	3.10	2.60	2.30	2.55	3.20	2.60	2.30	1.80	1.80	1.80		1.80	1.80	1.80	1.80	1.00	1.00	1.00	1.00	20.0
22.0	2.90	2.55	2.40	2.30	2.45	2.80	2.60	2.30	2.00	2.60	2.60	2.30	1.80	1.80	1.80	1.80	1.80	1.80	1.80	1.80	1.00	1.00	1.00	1.00	22.0
24.0	2.60	2.35	2.30		2.00	2.30	2.45	2.30	1.50	2.05	2.30	2.30	1.45	1.80	1.80	1.80	1.80	1.80	1.80	1.80	1.00	1.00	1.00	1.00	24.0
26.0	2.20				1.60	1.90	2.00		1.10	1.60	1.80	2.00	1.10	1.60	1.80	1.80	1.80	1.80	1.80	1.80	1.00	1.00	1.00	1.00	26.0
28.0					1.25	1.50	1.60		0.80	1.15	1.35	1.50	0.80	1.20	1.45	1.60	1.60	1.60	1.60	1.60	0.80	1.00	1.00	1.00	28.0
30.0					0.95	1.10			0.50	0.80	0.95		0.55	0.90	1.10	1.25	1.25	1.25	1.25	1.25	0.50	1.00	1.00	1.00	30.0
32.0					0.70					0.50	0.60			0.60	0.80						0.60	0.90	1.00		32.0
34.0															0.50							0.60	0.65		34.0
Critical boom angle	10°	30°	45°	60°	10°	30°	45°	60°	40°	40°	45°	60°	50°	50°	50°	60°	55°	57°	57°	60°					Critical boom angle

(Unit: Metric ton)

19 m Luffing jib



Working radius (m)	Outriggers fully extended (4.0 m) Over side																Working radius (m)								
	9.2 m Boom				15.35 m Boom				21.5 m Boom				27.65 m Boom					33.8 m Boom Working							
	Offset angle				Offset angle				Offset angle				Offset angle					Offset angle							
	10°	30°	45°	60°	10°	30°	45°	60°	10°	30°	45°	60°	10°	30°	45°	60°	10°	30°	45°	60°	10°	30°	45°	60°	
8.0	4.00								3.50																8.0
10.0	4.00				4.00				3.50								1.80								10.0
12.0	4.00				4.00				3.50								1.80				1.00				12.0
14.0	3.80	3.50			3.40	3.10			3.10	3.50							1.80				1.00				14.0
16.0	3.20	3.50	2.50		2.65	3.10			2.40	3.10							1.80	1.80			1.00				16.0
18.0	2.65	2.90	2.50		2.10	2.60	2.60		1.80	2.45	2.60						1.70	1.80			1.00	1.00			18.0
20.0	2.20	2.40	2.50	2.30	1.65	2.10	2.30	2.30	1.25	1.90	2.20	2.30	1.25	1.80	1.80		1.25	1.80	1.80	1.80	1.00	1.00	1.00	1.00	20.0
22.0	1.80	2.00	2.10	2.20	1.25	1.65	1.85	2.00	0.80	1.40	1.70	1.90	0.85	1.40	1.70	1.80	1.80	1.80	1.80	1.80	0.80	1.00	1.00	1.00	22.0
24.0	1.45	1.60	1.70		0.90	1.25	1.45	1.60		0.95	1.25	1.40		1.00	1.30	1.50	1.50	1.50	1.50	1.50	1.00	1.00	1.00	1.00	24.0
26.0	1.20				0.60	0.90	1.05			0.60	0.85	1.00		0.70	0.95	1.10	1.10	1.10	1.10	1.10	0.70	0.90	1.00		26.0
28.0						0.60	0.70										0.65	0.75	0.75	0.75		0.65	0.80		28.0
Critical boom angle	10°	30°	45°	60°	30°	30°	45°	60°	57°	57°	60°	60°	62°	63°	63°	65°	65°	65°	65°	66°	67°	68°	68°		Critical boom angle

(Unit: Metric ton)

جریفیل های کاتو و هیبتچی سومیتومو در ایران

می فروش و خدمات پس از فروش

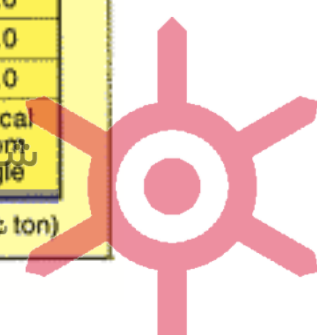

NOTE:**— ON LUFFING JIB —**

- 1.) The rated lifting capacities are the maximum load guaranteed on a firm level ground and include the weight of hook block and other lifting equipment. The capacities enclosed with bold lines are based on the structural strength of machine and the others are based on the stability of machine.

Hook	for 12 ton	for 4 ton
Weight (kg)	220	120

- 2.) The working radii as given in the table are the actual values including the deflection of the boom. Therefore, operate the machine based on the working radius.
- 3.) Critical boom angles for each boom length are shown on bottom-most line of lifting capacity table.
If the boom angle is lowered to less than the critical boom angle, the machine will tip over without load. Therefore, never lower the boom below these angles.
- 4.) The standard number of parts of line is shown in the table below.

Jib length	14 m	19m
Parts of line	2 or 1	1

- 5.) The rated lifting capacities of 14 m jib represent the value for operation with 2 parts of line.
With 1 part of line, maximum should be limited to 4000 kg.
- 6.) If the jib offset angle exceeds the specified value, the crane should be operated with the rated lifting capacity either for the specified offset angle or for one step larger offset angle, whichever is smaller.
- 7.) Lifting capacities over side vary with outrigger width extended. Operation must be carried out according to the lifting capacity table based on the corresponding outrigger width.
Lifting capacities over front/rear are equal to those with outriggers fully extended.
- 8.) Free fall is adopted in principle to lower the hook only. If it is necessary to lower a load by free fall, its weight should be less than 20% of the rated lifting capacity any abrupt braking should not be allowed.
- 9.) The machine will tip over or be damaged if operated with a load exceeding that specified in the rated lifting capacity table or not conforming to correct handling.
If such trouble occurs, the machine will not be warranted.

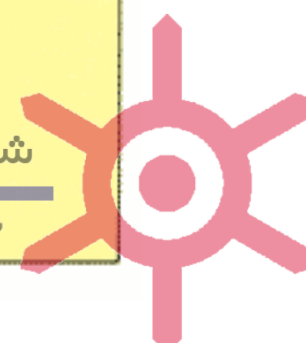

KR-500 Rough Terrain Crane

ROUGHTERR

Minimum Road Width for Right-Angle Turn

Right turn in 2-wheel steering mode

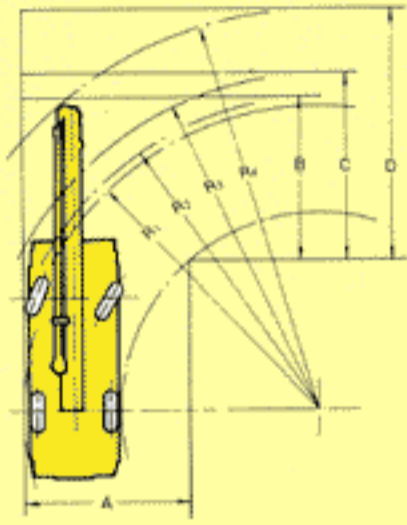

$R_1 = 10.5$ m (Minimum turning radius)
 $R_2 = 10.8$ m (Turning radius of extremely outer tire)
 $R_3 = 11.7$ m (Chassis turning radius)
 $R_4 = 13.8$ m (Boom end turning radius)

$A = 5.6$ m (Width of entrance)
 $B = 5.6$ m (Width of wheel exit)
 $C = 6.5$ m (Width of chassis exit)
 $D = 8.0$ m (Width of exit at end of boom)

Right turn in 4-wheel steering mode

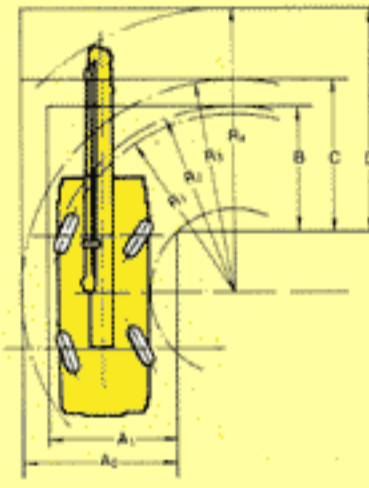

$R_1 = 6.2$ m (Minimum turning radius)
 $R_2 = 6.5$ m (Turning radius of extremely outer tire)
 $R_3 = 7.5$ m (Chassis turning radius)
 $R_4 = 9.2$ m (Boom end turning radius)

$A_0 = 5.3$ m (Width of entrance)
 $A_1 = 4.3$ m (Width of wheel entrance)
 $B = 4.3$ m (Width of wheel exit)
 $C = 5.3$ m (Width of chassis exit)
 $D = 7.0$ m (Width of exit at end of boom)

Note: The above values are based on calculations.

Address inquiries to:

* NOTE: Illustrations may include optional equipment. KATO products and specifications are subject to improvements and changes without notice.



KATO WORKS CO.,LTD.

9-37, Higashi-ohi 1-chome, Shinagawa-ku, Tokyo, 140, Japan

Phone : Head Office Tokyo (03) 458-1111

Export Dep't Tokyo (03) 458-1115

Telex : 222-4519 (CR KATO J)

Fax. : Tokyo (03) 458-1152 (سهامی خاص) شرکت ایمن مرکزی اروند

Cable : CRANEKATO TOKYO نمایندگی رسمی فروش و خدمات پس از فروش جرثقیل های کاتو و هیتاچی سومیتومو در ایران

