

CR-100

CITYRANGE CRANE

SPECIFICATION

■ CRANE SPECIFICATION

Performance

Maximum rated lifting capacity:	10 metric tons × 2.5m
Boom length:	5.5m – 23.5m (6 section)
Fly jib length (OPTION):	2.5m (1 section, offset, 15°, 30° & 45° optional) (Deck stowed, detachable fly jib)
Maximum lifting height:	Boom 24.5m (23.5m Boom) Jib 26.7m (23.5m Boom + 2.5m fly jib offset 15°)
Boom derricking angle:	–9 – 81°
* Boom derricking time:	30sec. (–9° – 81°)
* Boom extending time:	56sec. (5.5m – 23.5m)
* Hoisting line speed (winch up)	
Main winch:	112m/min. (at 4th layer)
Auxiliary winch:	104m/min. (at 3rd layer)
* Hoisting hook speed (Winch up)	
Main winch (parts of line; 8):	14m/min. (at 4th layer)
Auxiliary winch (parts of line; 1):	104m/min. (at 3rd layer)
* Slewing speed:	2.3min ⁻¹
(Speed: Subject to no load)	

Hoisting Ropes

Main winch;	Diameter: 10mm	Length: 130m
Auxiliary winch;	Diameter: 10mm	Length: 58m

Hydraulic System

Oil pump:	4 pumps, plunger and gear type
Hoisting motor:	Axial plunger type
Slewing motor:	Axial plunger type
Cylinder:	Double acting type
Control valve:	Double acting with integral check and relief valves
Oil reservoir capacity:	150lit.

Winch System

Main winch & Auxiliary winch:	Driven by axial plunger type hoisting motor with gear reduction. Controlled independently by respective operating lever. Equipped with automatic brake.
-------------------------------	---

Safety devices

Safe load indicator: KATO ACS (Automatic Crane Stopper) Include;	Over unwinding warning *Working radius digital display *Boom length digital display *Number of parts of line digital display (* = Selected display)
Safe level indicator lamps	Working range limit system with working area restriction display
Actual load digital display	Outside warning device
Rated lifting capacity digital display	Voice alarm (Option)
Trouble warning lamp	
Boom operation status display	
Fly jib offset angle display	
Outrigger setting status display	
Slewing area display	
Winch drum indicator	
Boom falling prevention device	
Hoisting limiter	
Winch drum lowering limiter	
Automatic winch brake	
Irregular winding prevention device	
Hydraulic safety valve	
Control pedal lock device for Main winch operation	
Control pedal lock device for Aux. winch operation	
Mechanical slewing lock	
Mechanical slewing brake	

Option

2.5m Fly jib (Deck stowed, detachable fly jib)
Amplifier
English voice alarm of ACS.

■ CARRIER SPECIFICATION

General dimensions & G.V.W.

Overall length:	7430mm
Overall width:	1995mm
Overall height:	2835mm
Wheel base:	2750mm
Treads; Front & Rear:	1680mm
Center to center of extended outriggers:	4500mm (Fully extended) 3200mm (Intermediately extended) 1640mm (Blocked on vertical cylinders)
Gross vehicle weight:	12,900kg
Front	6350kg
Rear	6550kg

Carrier

Drive system:	4 × 2/4 × 4
Maximum traveling speed:	49km/h
Gradeability (tanθ):	60% (computed @G.V.W. = 12,900kg)
Minimum turning radius:	3.92m (4 wheel steer)
(center of extreme outer tyre):	6.5m (2 wheel steer)
Engine:	
Maker:	Hino Motors, Ltd.
Model:	EA-WO4C-TV
Type:	4 cycle, water cooled, direct injection, turbo-charged diesel engine with inter-cooling
No. of cylinder:	4
Piston displacement:	3839cc
Max. output horsepower:	118KW/3000min ⁻¹
Max. output torque:	471N-m/1,600min ⁻¹
NOTE:	The engine emission is in accordance with 97/68/EC.
Torque converter:	Engine mounted 3 elements 1 stage (with lock up clutch)
Transmission:	Remote mounted full automatic with transfer gear box 4 forward & 1 reverse speed (with Hi-Low selector)
Axle;	Front & Rear: Planetary, drive/steer type
Suspension;	Front & Rear: Taper-leaf spring
Steering:	Full hydraulic power steering Completely independent front and rear steering (with automatic rear wheel steering lock system)
Brake;	Service brake: Air-over hydraulic disk brake on front wheels Air-over hydraulic drum brake on rear wheels (2 circuit). Equipped with service brake lock
Parking brake:	Spring applied, electrically air released parking brake mounted on rear wheels, internal expanding type
Auxiliary brake:	Exhaust brake
Electric system:	24V
Alternator:	24V – 45A
Battery:	(12V – 95E41R) × 2
Fuel tank capacity:	250lit.
Driver's cab:	All steel welded construction, 1 person, Air-conditioner (OPTION)
Tyre size;	Front & Rear: 11R22.5 148/145
Safety devices:	Emergency steering device Brake fluid leak warning device Seat belt Service brake lock Engine overrun alarm Over-shift prevention device Radiator coolant leakage warning device Motor driven retractable side mirrors Mirror heater

شرکت ایمن مرکزی آروند (سهامی خاص)
توسعه و فروش ماشین های عمرانی و تجهیزات
در تهران و شهرستان های اطراف آن
پس از فروش میتونم در ایران

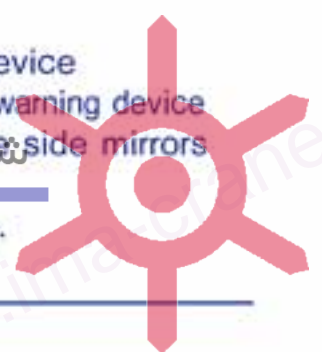

■RATED LIFTING CAPACITY(1)

Based on * ISO 4305 * BS 1757 : 1986 * DIN 15019-2

Working radius (m)	Outriggers fully extended(4.5m) 360° full range						Outriggers intermediately extended(3.2m) 360° full range						Outriggers completely retracted (blocked on vertical cylinders) – 360° full range					
	5.5m Boom	9.1m Boom	12.7m Boom	16.3 Boom	19.9m Boom	23.5m Boom	5.5m Boom	9.1m Boom	12.7m Boom	16.3 Boom	19.9m Boom	23.5m Boom	5.5m Boom	9.1m Boom	12.7m Boom	16.3 Boom	19.9m Boom	23.5m Boom
1.5	10.00	5.00	5.00				10.00	5.00	5.00				8.00	5.00	4.90			
2.0	10.00	5.00	5.00	4.00			10.00	5.00	5.00	4.00			5.50	4.00	3.50	3.25		
2.5	10.00	5.00	5.00	4.00			10.00	5.00	5.00	4.00			3.70	3.15	2.60	2.50		
3.0	8.00	5.00	5.00	4.00	4.00		8.00	5.00	5.00	4.00	4.00		2.70	2.35	1.95	1.95	1.90	
3.5	6.10	5.00	5.00	4.00	4.00	2.30	6.10	5.00	5.00	4.00	4.00	2.30	2.10	1.85	1.50	1.55	1.55	1.50
4.0	5.20	5.00	5.00	4.00	4.00	2.30	5.20	4.45	4.30	4.00	4.00	2.30	1.60	1.45	1.15	1.25	1.25	1.20
4.5		5.00	4.55	4.00	3.70	2.30		3.90	3.55	3.50	3.40	2.30		1.10	0.85	1.00	1.00	1.00
5.0		4.40	4.10	3.70	3.40	2.30		3.35	3.00	3.00	2.95	2.30		0.85	0.65	0.80	0.85	0.85
5.5		3.95	3.70	3.40	3.10	2.30		2.80	2.55	2.60	2.55	2.30		0.65	0.45	0.60	0.65	0.70
6.0		3.55	3.35	3.15	2.85	2.30		2.35	2.20	2.25	2.25	2.10		0.50	0.30	0.45	0.55	0.55
6.5		3.15	3.05	2.90	2.60	2.15		2.00	1.90	2.00	2.00	1.95		0.35	0.20	0.35	0.40	0.45
7.0		2.80	2.80	2.65	2.40	2.00		1.75	1.65	1.75	1.75	1.75		0.25		0.25	0.30	0.35
8.0		2.50	2.30	2.25	2.05	1.75		1.50	1.20	1.35	1.40	1.40						
9.0		(7.5m)	1.90	1.95	1.80	1.55		(7.5m)	0.90	1.05	1.10	1.15						
10.0			1.50	1.70	1.60	1.40			0.65	0.80	0.90	0.90						
11.0			1.20	1.40	1.40	1.25			0.45	0.60	0.70	0.75						
12.0				1.15	1.25	1.15				0.45	0.55	0.60						
13.0				0.95	1.05	1.05				0.30	0.45	0.50						
14.0				0.78	0.90	0.95				0.20	0.35	0.35						
15.0				0.70	0.75	0.84					0.25	0.30						
16.0				(14.5m)	0.63	0.70						0.20						
17.0					0.53	0.60												
18.0					0.44	0.50												
19.0						0.42												
20.0						0.35												
21.0						0.28												
22.0						0.24												
Standard hook	for 10 ton						for 10 ton						for 10 ton					
Hook mass	80kg						80kg						80kg					
Parts of line	8	4					8	4					8	4				
Critical boom angle	—	—	—	—	—	—	—	—	—	—	25°	35°	—	—	52°	59°	64°	68°

(Unit:Metric ton)

■RATED LIFTING CAPACITY(2)

Based on * ISO 4305 * BS 1757 : 1986 * DIN 15019-2

23.5m Boom + 2.5m Jib													
Boom angle (°)	Outriggers fully extended (4.5m) – 360° full range						Outriggers intermediately extended (3.2m) – 360° full range						
	Offset 15°		Offset 30°		Offset 45°		Boom angle (°)	Offset 15°		Offset 30°		Offset 45°	
	Working radius(m)	Load (t)	Working radius(m)	Load (t)	Working radius(m)	Load (t)		Working radius(m)	Load (t)	Working radius(m)	Load (t)	Working radius(m)	Load (t)
81	4.0	1.20	4.5	1.00	5.0	0.80	81	4.0	1.20	4.5	1.00	5.0	0.80
77.5	5.7	1.20	6.2	1.00	6.5	0.80	77.5	5.7	1.20	6.2	1.00	6.5	0.80
73	7.7	1.20	8.2	1.00	8.4	0.76	73	7.7	1.20	8.2	1.00	8.4	0.76
70	8.9	1.08	9.4	0.92	9.6	0.74	70	8.9	1.08	9.4	0.92	9.6	0.74
65	11.0	0.90	11.4	0.81	11.6	0.70	67.5	10.0	0.98	10.4	0.86	10.7	0.72
60	12.9	0.80	13.3	0.73	13.5	0.68	65	11.0	0.81	11.4	0.74	11.6	0.70
55	14.8	0.70	15.1	0.66	15.2	0.63	60	12.9	0.54	13.3	0.52	13.4	0.50
50	16.5	0.64	16.7	0.61	16.8	0.59	55	14.7	0.35	15.1	0.33	15.2	0.33
46.5	17.6	0.58	17.9	0.57	18.0	0.56	50	16.5	0.20	16.7	0.20	16.8	0.20
40	19.4	0.42	19.7	0.41			Standard hook	for 1.4 ton					
32	21.4	0.28	21.5	0.28			Hook mass	25kg					
25	22.7	0.20					Parts of line	1					
Standard hook	for 1.4 ton						Critical boom angle	49°	49°		49°		
Hook mass	25kg												
Parts of line	1												
Critical boom angle	15°	30°			45°								

(Unit:Metric ton)

شرکت ایمن مرکزی اروند (سهامی خاص)

نمایندگی رسمی فروش و خدمات پس از فروش
جرثقیل های کاتو و هیتاچی سومیتومو در ایران

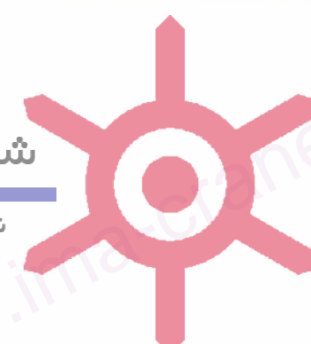

■ RATED LIFTING CAPACITY (3)

Based on *ISO 4305 *BS 1757:1986 *DIN 15019-2

Without outriggers Stationary on rubber, Pick & carry (less than 2 km/h) (over front with slewing lock pin inserted)		
Working radius (m)	Over front	
	5.5m Boom	9.1m Boom
2.0	1.10	
3.0	1.10	
4.0	1.00	0.60
7.5		0.50
Standard hook	for 10 ton	
Hook mass	80 kg	
Parts of line	4	
Critical boom angle		

(Unit:Metric ton)

Notes for the Rated Lifting Capacity Chart

■ Rated lifting capacity charts (1) and (2)

When outriggers are used.

- The rated lifting capacity chart indicates the maximum load which can be lifted by this crane provided it is level and standing on firm, level ground. It includes the mass of the hook and all other slings etc. The area of the rated lifting capacity chart surrounded by a thick black line is the area in which capacity is determined by the structural strength of the crane. Elsewhere the crane's stability is the deciding factor.
- The working radius is based on the actual radius including boom and jib deflection. Always use the actual working radius as the standard criterion for crane operation.
- The jib working radius is based on the jib mounted on the end of the 23.5m boom. If the boom is at any other length use the boom angle alone as the standard criterion for crane operation. (The jib is optional.)
- Never operate the jib when the outriggers are fully retracted. (The jib is optional.)
- The rated lifting capacity of the rooster sheave is the rated lifting capacity of the boom minus the mass of all attached slings etc. to the boom, with an upper limit of 1,400kg. {The hook for use with the rooster sheave is the 1.4 ton hook (mass 25kg) with one part of line.}
- If the boom length exceeds the rated length use the rated lifting capacity for the rated length or for the next highest boom length step, whichever gives the smaller rated lifting capacity.
- If you are working with the boom while the jib is rigged subtract 120kg from the rated lifting capacity as well as subtracting the mass of the slings etc. Do not use the rooster sheave in this situation. (The jib is optional.)
- In whatever working conditions the corresponding boom critical angle is shown in the table. Lowering the boom below the critical angle could cause the machine to tip over even if the crane is not carrying any added load.
- The standard parts of line for each boom length are as shown in the table. If you work with a non-standard number of parts of line take 1,300kg as the maximum load on any part of the wire rope.

- Crane operation is permissible up to a wind speed of 10m/s. Even in relatively light wind conditions, extra care should be taken when handling loads presenting large wind catching areas.
- Kato bears no liability whatsoever for damage, crane tipping or other accident caused by misuse of the crane, exceeding the rated lifting capacity or differing from the directions contained in the instruction manual and the warning labels.

■ Rated lifting capacity charts (3)

When outriggers are not used.

- The rated lifting capacity chart indicates the maximum load which can be lifted by this crane provided it is standing on firm, level ground with all tyres inflated to the rated pressure. It includes the mass of the hook and all other slings etc.
- Operation over side is not permitted. Operate this machine only over front with the slewing lock pin inserted.
- Do not work with the jib or with a boom length of more than 9.1m. (The jib is optional.)
- Never derrick the boom above 60°, which can cause a dangerous result.
- Always engage the parking brake before you start stationary crane-on-rubber operation.
- For pick and carry operation the high/low speed switch must be switched to "ON"(low range) and the shift lever set to speed 1.
- For pick and carry operation lower the load to just above the ground and keep your speed strictly less than 2km/h to avoid swinging the load. Take particular care to avoid sharp cornering and sudden starts and stops.
- Never operate the crane during pick and carry operation. The slewing brake must always be engaged with the slewing lock pin inserted.
- Other than the above precautions observe points (2), (5), (6), (8), (9), (10) and (11) of the section "Precautions on outrigger use"

شرکت ایمن مرکزی آروند (سهامی خاص)

نماینده رسمی فروش و خدمات پس از فروش
جرثقیل های کاتو و هیتاچی سومیتومو در ایران

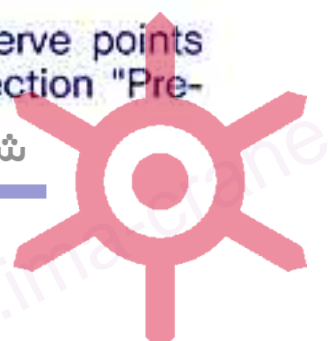

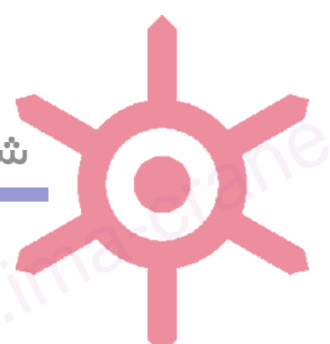
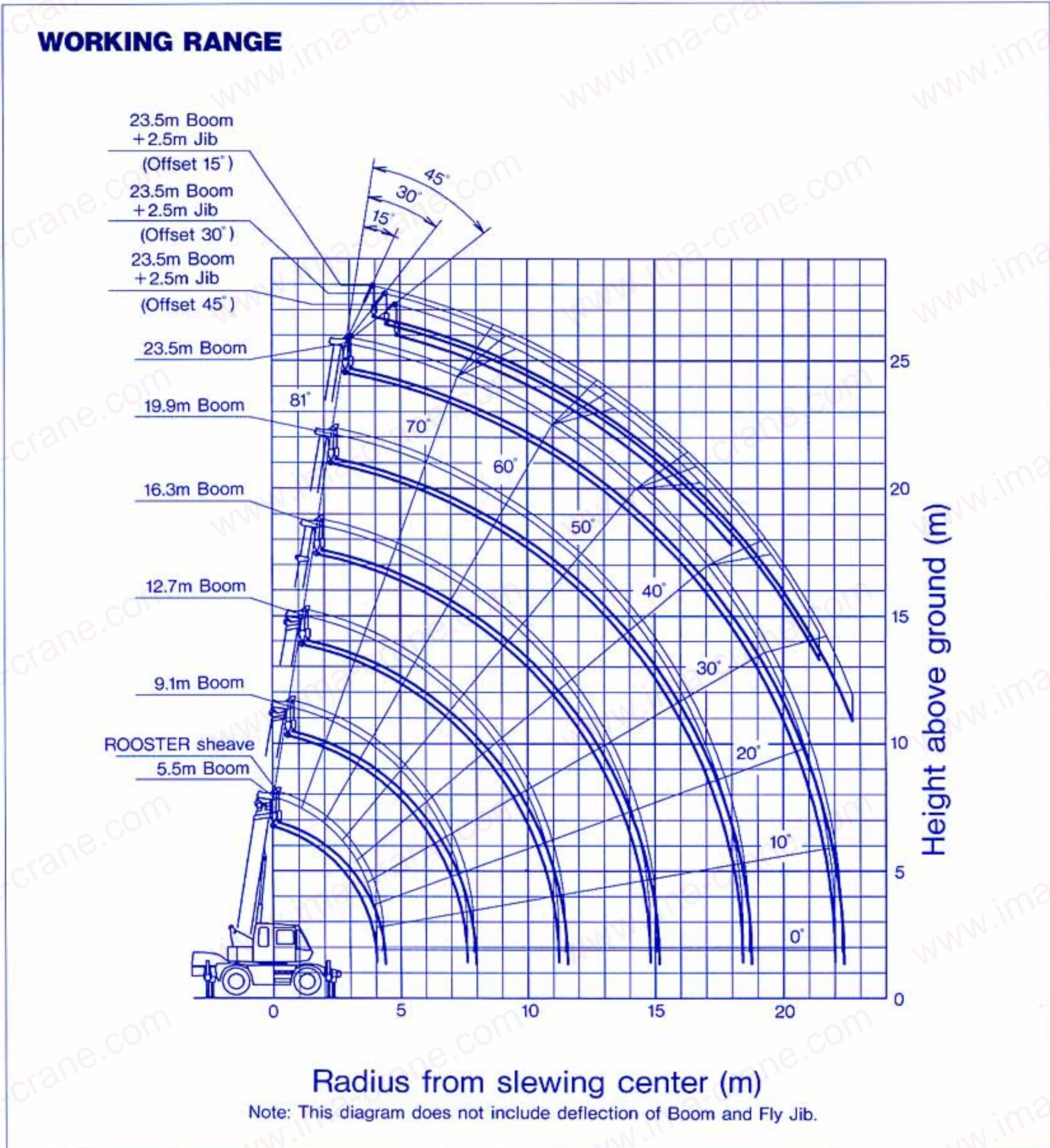

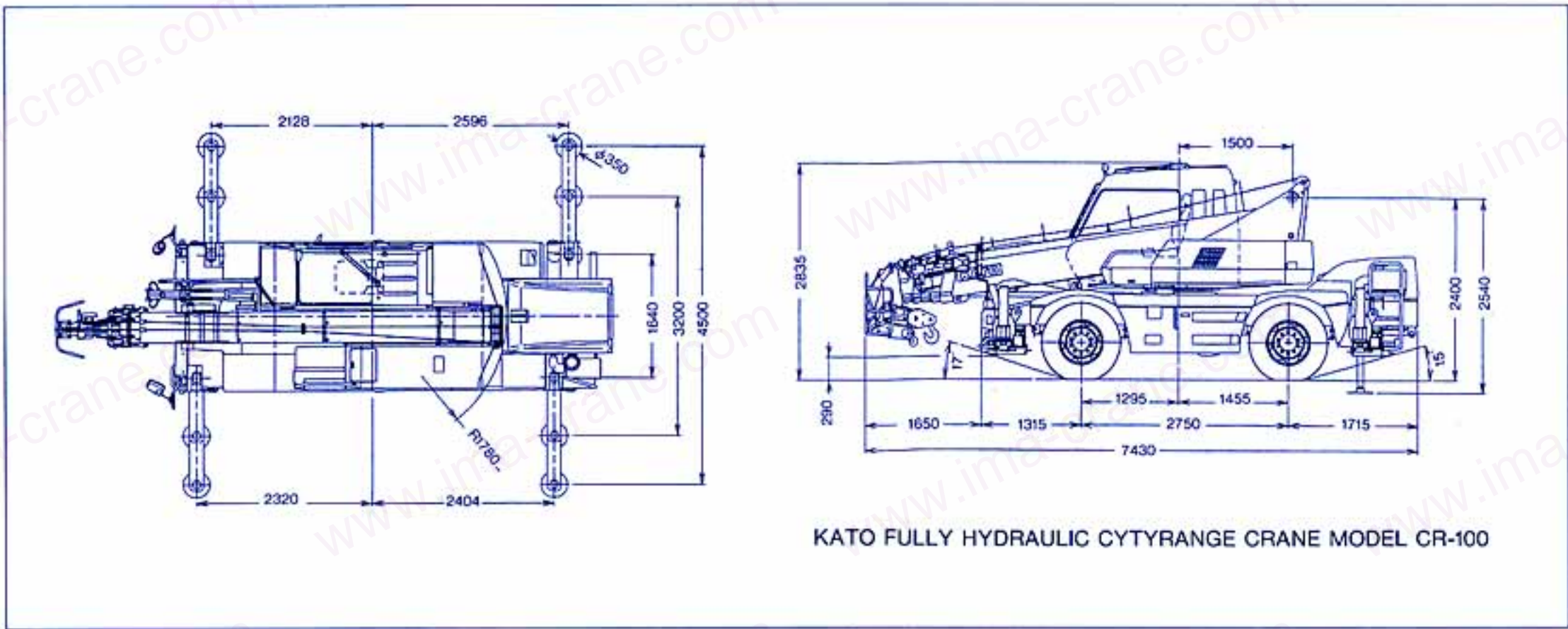

KATO FULLY HYDRAULIC CYTYRANGE CRANE MODEL CR-100

Minimum Road Width for Right-Angle Turn

Right turn in two-wheel steering mode

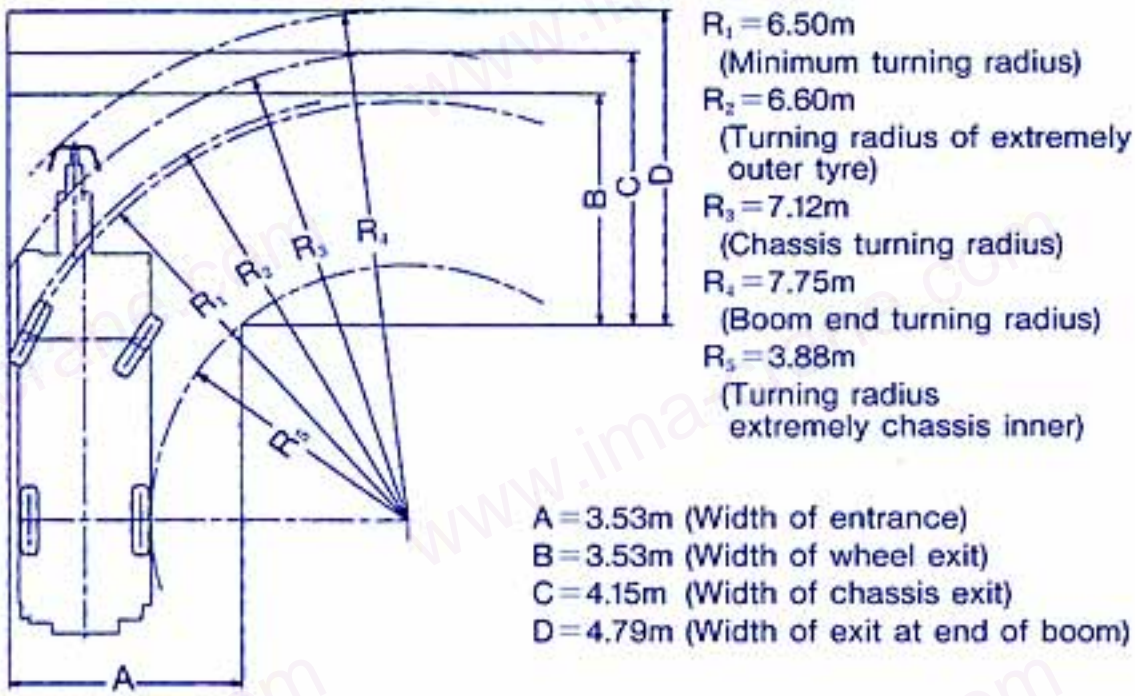

Right turn in 4-wheel steering mode

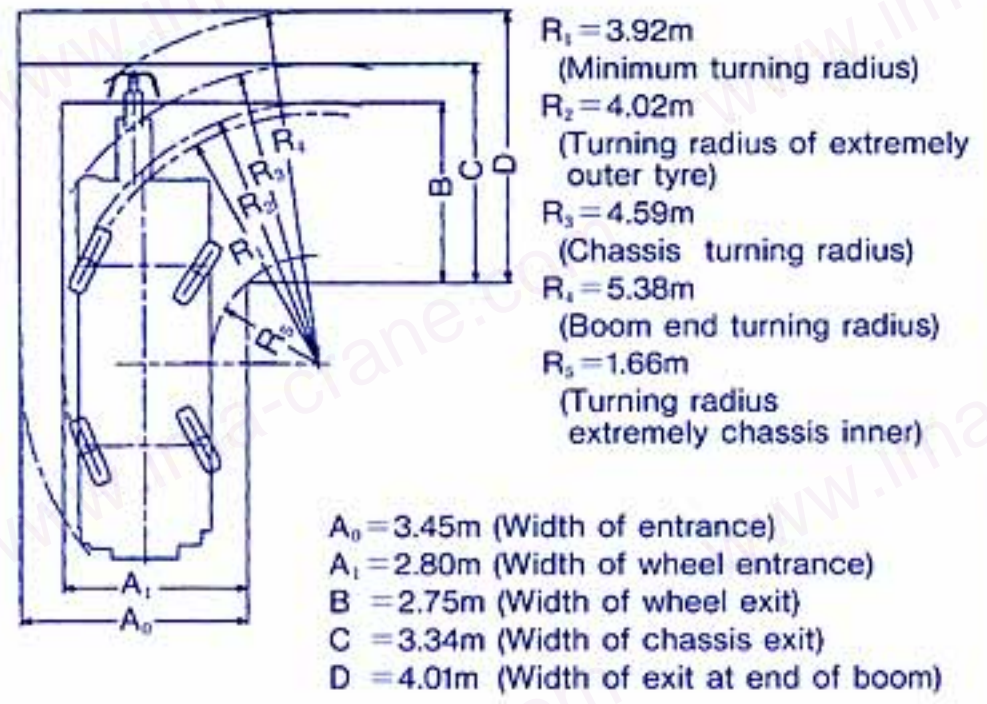

Note: The above values are based on calculations.

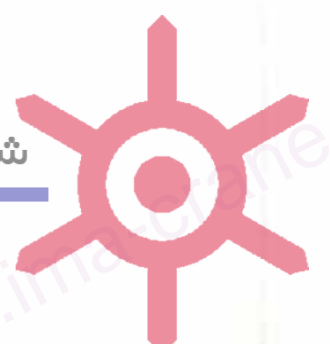

www.ima-crane.com

*NOTE: KATO products and specifications are subject to improvements and changes without notice.

KATO

QUALITY & EXPERIENCE
SINCE 1895

KATO WORKS CO.,LTD.

9-37, Higashi-ohi 1-chome, Shinagawa-ku, Tokyo 140-0011 Japan.

Tel. :Head Office Tokyo(03)3458-1111

Overseas Marketing Department Tokyo(03)3458-1115

Telex :222-4519(CBKATO) شرکت ایمن مرکزی

Fax. :Tokyo(03)3458-1152

Cable: CRANEKATO TOKYO

نمایندگی رسمی فروش و خدمات پس از فروش
در تقبیل های کاتو و هیتاچی سومیتومو در ایران

CR100 1-1
E549(Hp)Printed in Japan

