

SCX 1500A-3

HYDRAULIC CRAWLER CRANE

Specifications & Lifting Capacities

Hoist Rope 28mm

HITACHI SUMITOMO



Variation of The Attachment

Line Speed *	Front / Rear Winch (Rated with 13.5 t load)	m/min	110 (45)
	Third Winch (Rated with 12 t load)		95 (30)
	Boom Hoist Winch		44
Swing Speed	min ⁻¹ (rpm)		1.8
Travel Speed High / Low *	km/h		1.5 / 0.9
Gradeability	% (Degree)		30 (17)
Engine Model			CUMMINS QSB6.7 (Stage IV / Tier 4 f)
Engine Rated Output Power	kW/min ⁻¹ (ps/rpm)		201 / 2000 (273 / 2000)

Note : Speeds marked with "*" may vary depending on load applied.

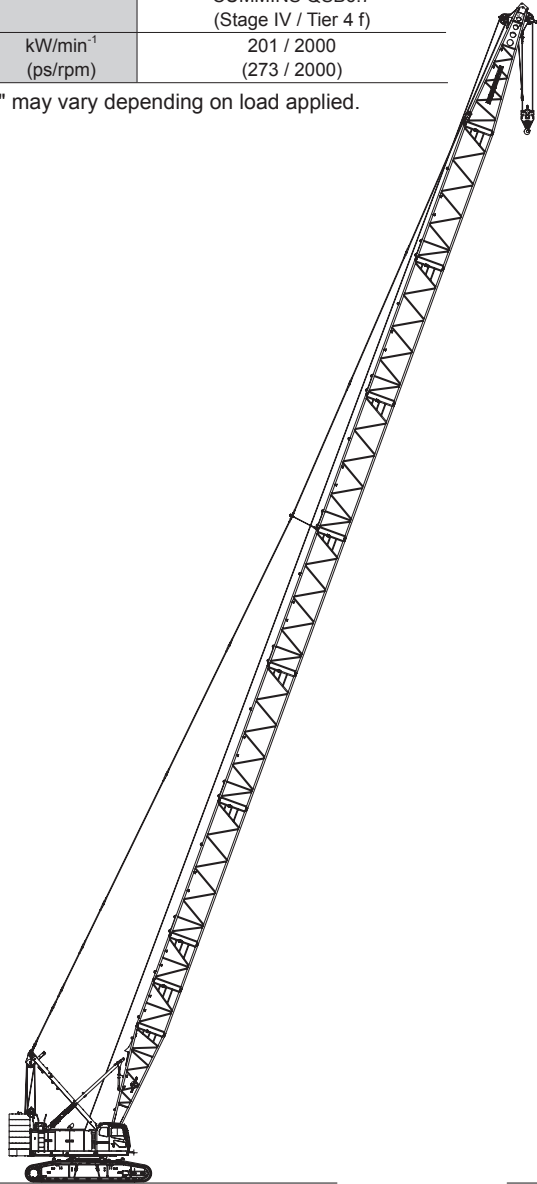

**Crane Specification
(Boom Longest Length)**

Boom Length	m	15 to 75
Ground Contact Pressure	kPa (kgf/cm ²)	110 (1.12) (Boom longest length with 35 t hook)
Overall Operating Weight	t	Approximately 148 (Boom longest length with 35 t hook)

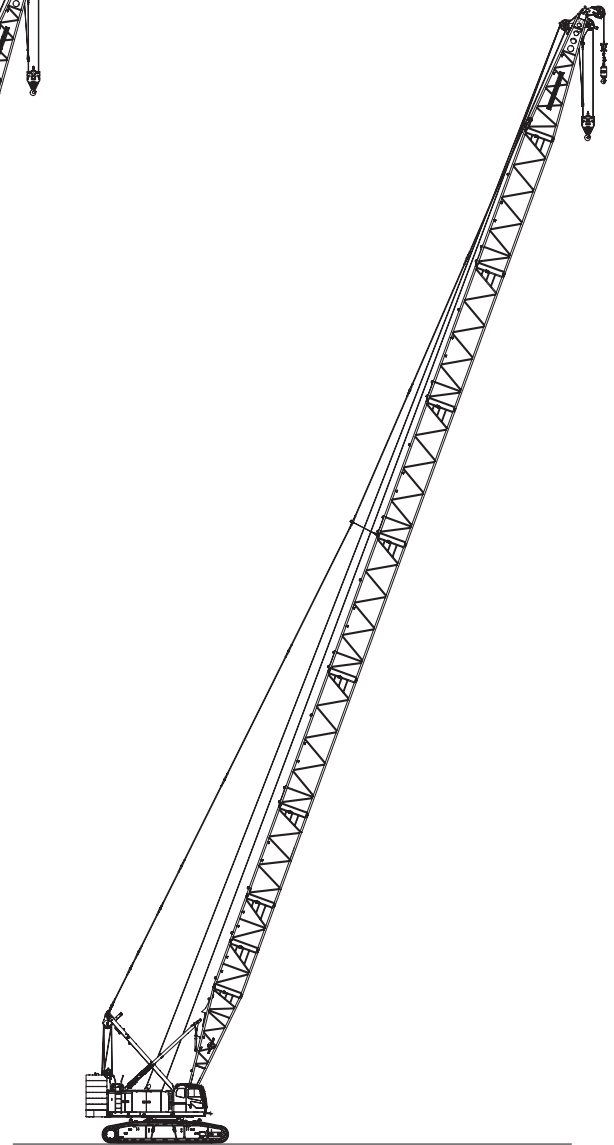

**Crane Specification
(Boom Longest Length with Aux. Sheave)**

Boom Length	m	15 to 72
Ground Contact Pressure	kPa (kgf/cm ²)	111 (1.13) (Boom longest length + 35 t aux. sheave + 13.5 t hook attached)
Overall Operating Weight	t	Approximately 149 (Boom longest length + 35 t aux. sheave + 13.5 t hook attached)

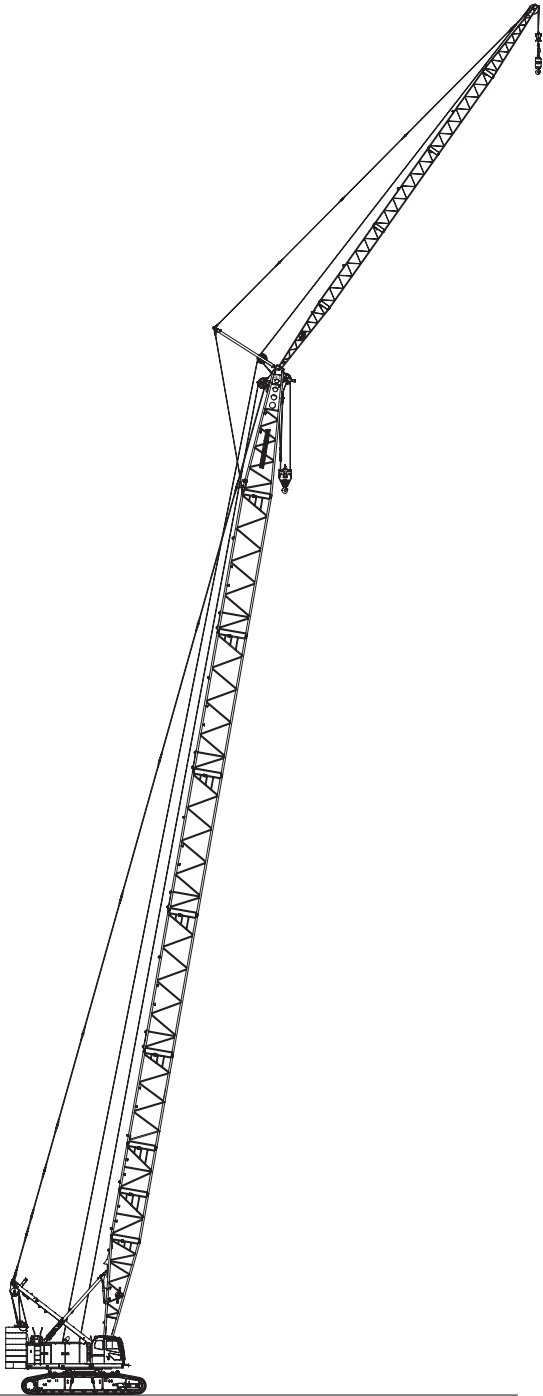

**Crane Specification
(Boom Longest Length with Crane Jib)**

Boom Length	m	24 to 63
Crane Jib Length	m	10 to 28
Boom + Crane Jib Longest Length	m	63 + 28
Ground Contact Pressure	kPa (kgf/cm ²)	111 (1.13) (Boom + crane jib longest length 35 t + 13.5 t hook attached)
Overall Operating Weight	t	Approximately 149 (Boom + crane jib longest length 35 t + 13.5 t hook attached)

VARIATION

Variation of The Attachment	2
------------------------------------	----------

SPECIFICATIONS

Specifications	6
-----------------------	----------

Crane Specifications	7
-----------------------------	----------

Dimensions and Specifications	7
-------------------------------------	---

Boom and Crane Jib Configurations	8
---	---

Combination of Boom and Crane Jib (Offset Angle 10° and 30°)	9
--	---

Working Ranges	10
----------------------	----

■ Main Boom	10
-------------------	----

■ Aux. Sheave	11
---------------------	----

■ Crane Jib	12
-------------------	----

Gross Rated Load Table	13
------------------------------	----

■ Main Boom	13
-------------------	----

■ Aux. Sheave	14
---------------------	----

■ Main Boom with Aux. Sheave	15
------------------------------------	----

■ Crane Jib	16
-------------------	----

■ Main Boom with Crane Jib	23
----------------------------------	----

■ Main Boom (Using Third Winch)	30
---------------------------------------	----

■ Main Boom with Aux. Sheave (Using Third Winch)	31
--	----

Clamshell Specifications	32
---------------------------------	-----------

Dimensions and Specifications	32
-------------------------------------	----

■ Working Ranges	32
------------------------	----

■ Specifications	32
------------------------	----

■ Clamshell Bucket	32
--------------------------	----

■ Gross Rated Load Table	32
--------------------------------	----

TECHNICAL DATA

Weights and Dimensions of Disassembled Units	33
Weights and Dimensions List	33
Equipment List	38
Standard and Optional Equipment	38

Specifications

Engine

Model	CUMMINS QSB6.7
Type	4-cycle, Water-cooled, Direct injection, Turbo-charged, Diesel engine
Displacement	6.7 liters
Rated Output	201 kW / 2,000 min ⁻¹ (273 ps / 2,000 rpm)
Fuel Tank Capacity	450 liters
Notes	Engine meets Stage IV / Tier 4 f of engine exhaust gas emission regulations in USA, Europe, and Japan. Engine rated horsepower is based on international rating formula that includes engine alternator and without fan.

Control

Control System	Main actuators are actuated by main hydraulic system controlled with pilot hydraulic system. Safety devices are securely operated by combined various electronic control with hydraulic system. Working speed can be precisely controlled according to control lever stroke and control dials depending on work.
Control Levers	Designed and positioned based on ergonomics. Armchair lever type is standard. Cross operation lever type and front lever type are available as option.
Display Panel Design	8 inches size. Located to check work state easily without disturbing the view of the operator.

Hydraulic System

Hydraulic Oil Tank Capacity	320 liters		
Hydraulic Pump Capacity	Max.	31.4 MPa	
	P1	266 liters / min	for Front, Rear , boom hoist winch and travel
	P2	266 liters / min	for Front, Rear , third winch and travel
	P3	160 liters / min	for Swing , Jack and Sideframe connect
	P4	41 liters / min	Pilot control, Brake cooling, Reeving tagline, etc
	P5	41 liters / min	
	P6	41 liters / min	
	P7	32 liters / min	

Winch

Front and Rear Winch			
Winch	Front	Rear	
Rope Diameter	28 mm	28 mm	
Rope Length	Standard	255 m	160 m for Aux. sheave
	Winding Capacity	-	195 m for Crane jib
Line Pull	Rated	294 m	294 m
		132 kN	132 kN
Standard Equipment	Free fall winch with brake controlled by pedal operation. High-speed winching is possible by ECO winch mode with low engine speed under light loads.		
Boom Hoist Winch			
Rope Diameter	22.4 mm		
Rope Length	Incorporated	195 m	
Hydraulic motor with multi-disc brakes.			

Third Winch(Optional)		
Rope Diameter	26 mm	
Rope Length	Standard	220 m
	Winding Capacity	220 m
Line Pull	Rated	117 kN
Free fall winch with brake controlled by pedal operation.		

Swing System

Consisted of 2 hydraulic motors with reduction gear and multi-disc brakes and a swing bearing which has inner tooth. Optional swing brake pedal enables operator to control swing precisely.

Mast

Mast is box structure. Easy assemble for front attachment.

Counterweight

Upper Weight	Total Weight	56.4 ton
	9.1 ton Base Weight	1 piece
	8.1 ton Insert Weight	5 pieces
Lower Weight	6.8 ton Top Weight	1 piece
	Total Weight	9 ton
	4.5 ton Lower Weight	2 pieces

Carbody Frame

Welded steel construction with jack up device and crawler sideframe connect cylinders.

Crawler Sideframe

Frame	Welded steel box construction. Hook on and joint pin design for crawler sideframe connection to carbody frame.	
Crawler Shoe	Cast iron 965mm width flat shoes each side. 5 pieces each side.	
Upper Roller	Double flange type : 3 pieces	
	Single flange type : 2 pieces	
Lower Roller	11 pieces each side.	
	Forging heat treated steel with double flange type. 2 plane bearing with floating seal for lifetime lubrication.	
Travel Device	1 peace each side.	
	Hydraulic travel device (Hydraulic motor and reducer)	
	Travel speed (Gradability : 30%)	High : 1.5 km/h Low : 0.9 km/h

Crane Specifications

Dimensions and Specifications

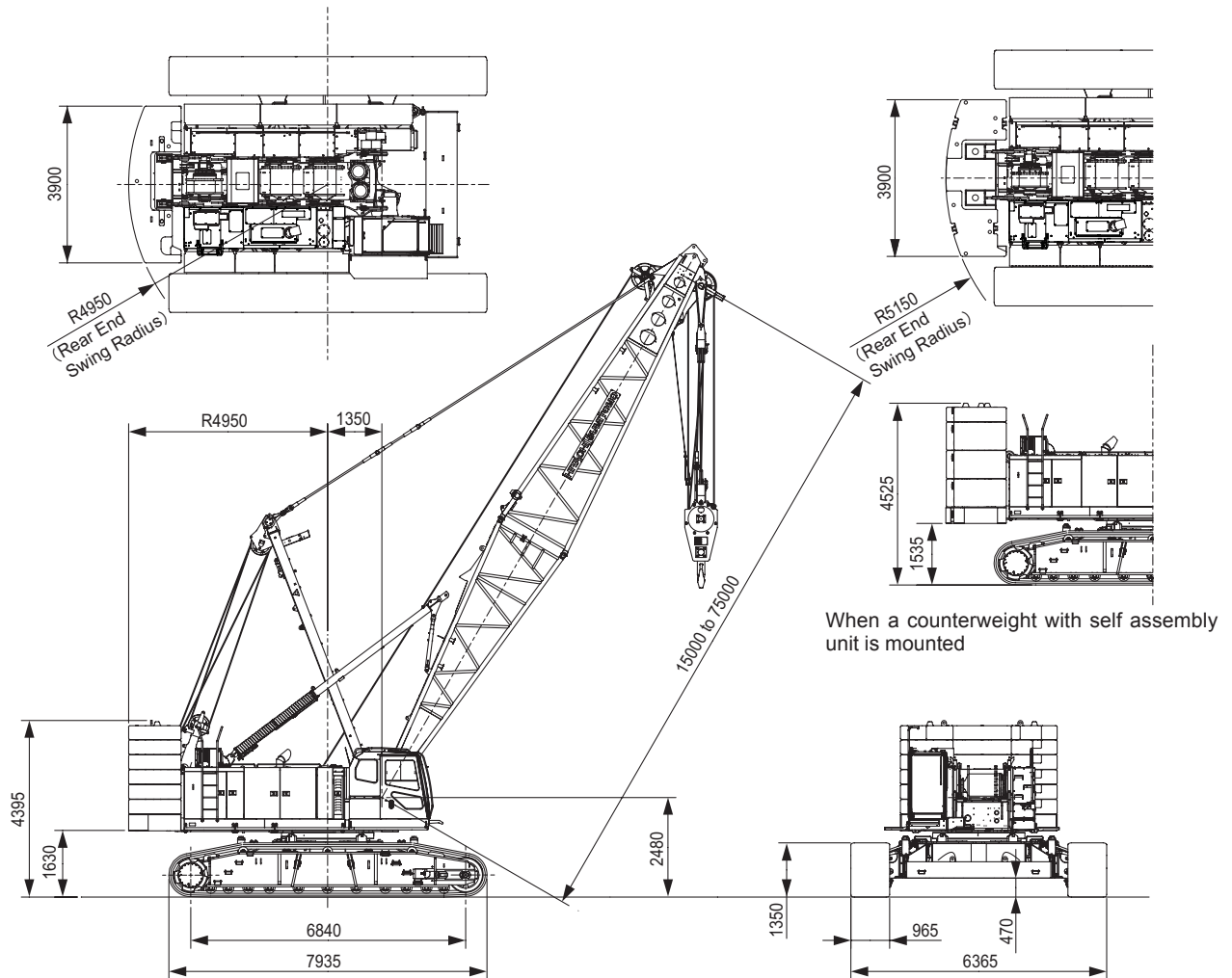

Crane Specifications

Max. Lifting Load × Working Radius	t × m	150×4.5
Basic Boom Length	m	15
Max. Boom Length	m	75
Max. Crane Jib Length	m	10 to 28
Max. Boom + Jib Length	m	63 + 28
Ground Contact Pressure	kPa (kgf/cm ²)	104 (1.06) (w / Basic Boom, 150 t Hook)
Overall Operating Weight	t	Approximately 140 (w / Basic Boom, 150 t Hook)

Hook Weight

150 t	2,350 kg
80 t	1,350 kg
35 t	900 kg
13.5 t	620 kg

NOTE : Data is expressed in SI units followed by conventional units in ().

Boom and Crane Jib Configurations

Boom (1/2)	
Boom Length (m)	Boom Configurations
15	
18	
21	
24	
27	
30	
33	
36	
39	
42	
45	

Boom (2/2)	
Boom Length (m)	Boom Configurations
48	
51	
54	
57	
60	
63	
66	
69	
72	
75	

▽ indicates the midpoint pendant rope connection position.

Aux. Sheave Installable Boom Length																					
Boom Length (m)	15	18	21	24	27	30	33	36	39	42	45	48	51	54	57	60	63	66	69	72	75
With Aux. Sheave	○	○	○	○	○	○	○	○	○	○	○	○	○	○	○	○	○	○	○	○	×

(○ : Attachable × : Not Attachable)

Check the pendant rope with referring to the imprints on the rope end.

Dimensions Not Shown In The Figure		Pendant Rope		
Symbols	Boom Length (m)	Length (m)	Rope Diameter (mm)	Imprint
3	3	1.2	40	□ · △ · 40 · 1.2 · C
6	6	2.6	40	□ · △ · 40 · 2.55 · C
7.5	7.5	3	40	□ · △ · 40 · 3 · C
9	9	6	40	□ · △ · 40 · 6 · C
		6.9	40	□ · △ · 40 · 6.9 · C
		9	40	□ · △ · 40 · 9 · C

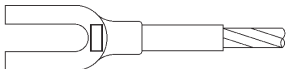

Combination of Boom and Crane Jib (Offset Angle 10° and 30°)

Combination of Boom and Crane Jib (Offset Angle 10° and 30°)

Boom Length (m)	15	18	21	24	27	30	33	36	39	42	45	48	51	54	57	60	63	66	69	72	75
Jib Length (m)	10	×	×	×	○	○	○	○	○	○	○	○	○	○	○	○	○	×	×	×	×
	16	×	×	×	○	○	○	○	○	○	○	○	○	○	○	○	○	×	×	×	×
	22	×	×	×	○	○	○	○	○	○	○	○	○	○	○	○	○	×	×	×	×
	28	×	×	×	○	○	○	○	○	○	○	○	○	○	○	○	○	×	×	×	×

(○ : Attachable × : Not Attachable)

Crane Jib (Offset Angle 10° and 30°)

Crane Jib Length (m)	Offset Angle	Crane Jib Configurations
10	10°	
	30°	
16	10°	
	30°	
22	10°	
	30°	
28	10°	
	30°	

Check the pendant rope with referring to the imprints on the rope end.

Dimensions Not Shown In The Figure

Symbols	Jib Length (m)
5	5
6	6

Jib Pendant Rope

Length (m)	Rope Diameter (mm)	Imprint
1.4	24	□ · △ · 24 · 1.4 · S
5.7	24	□ · △ · 24 · 5.7 · S
9.6	24	□ · △ · 24 · 9.6 · S
10	26	□ · △ · 26 · 10 · S

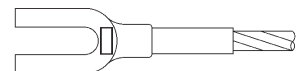

Working Ranges

■ Main Boom

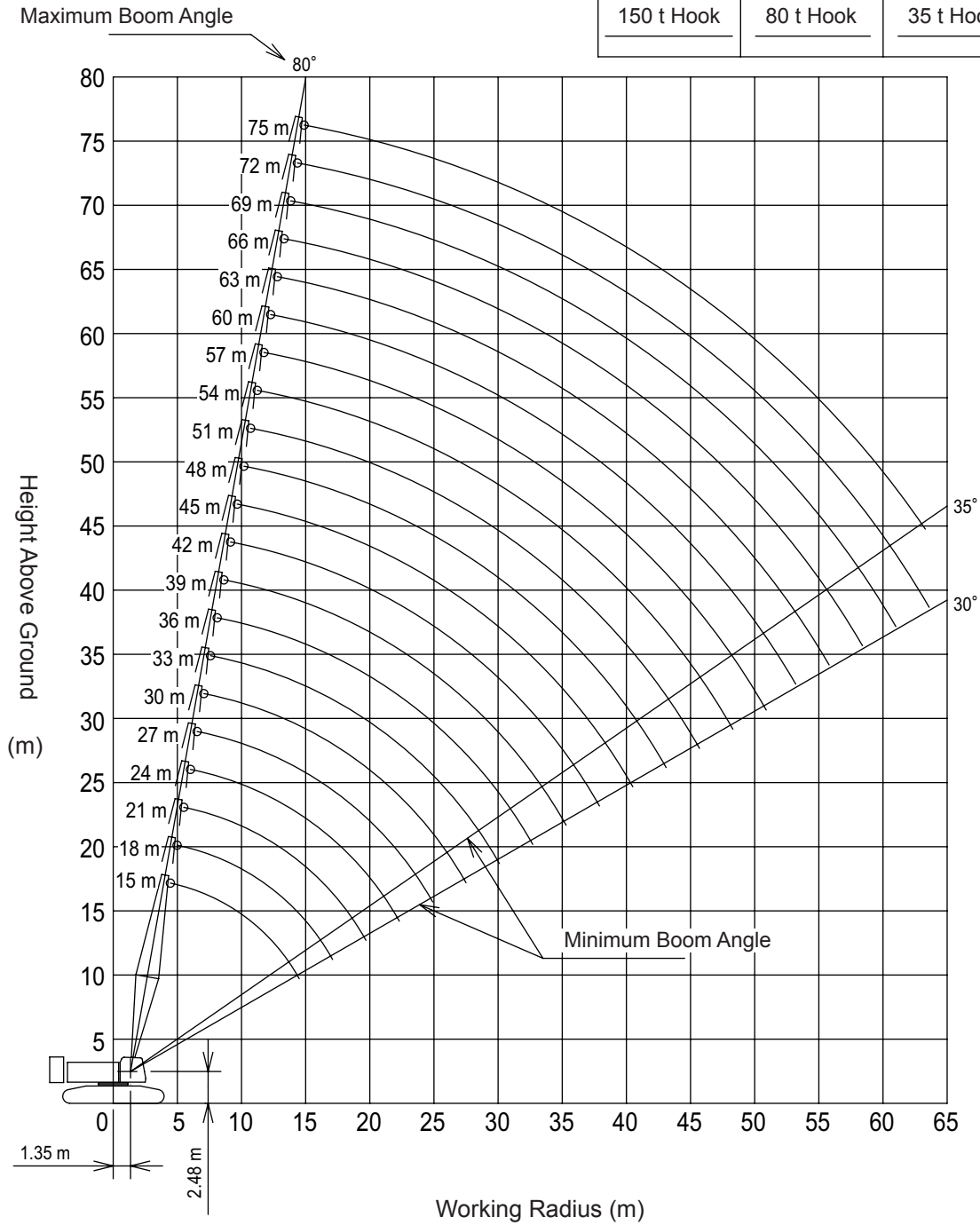
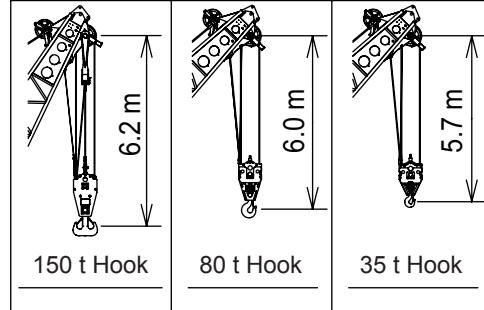

■ Aux. Sheave

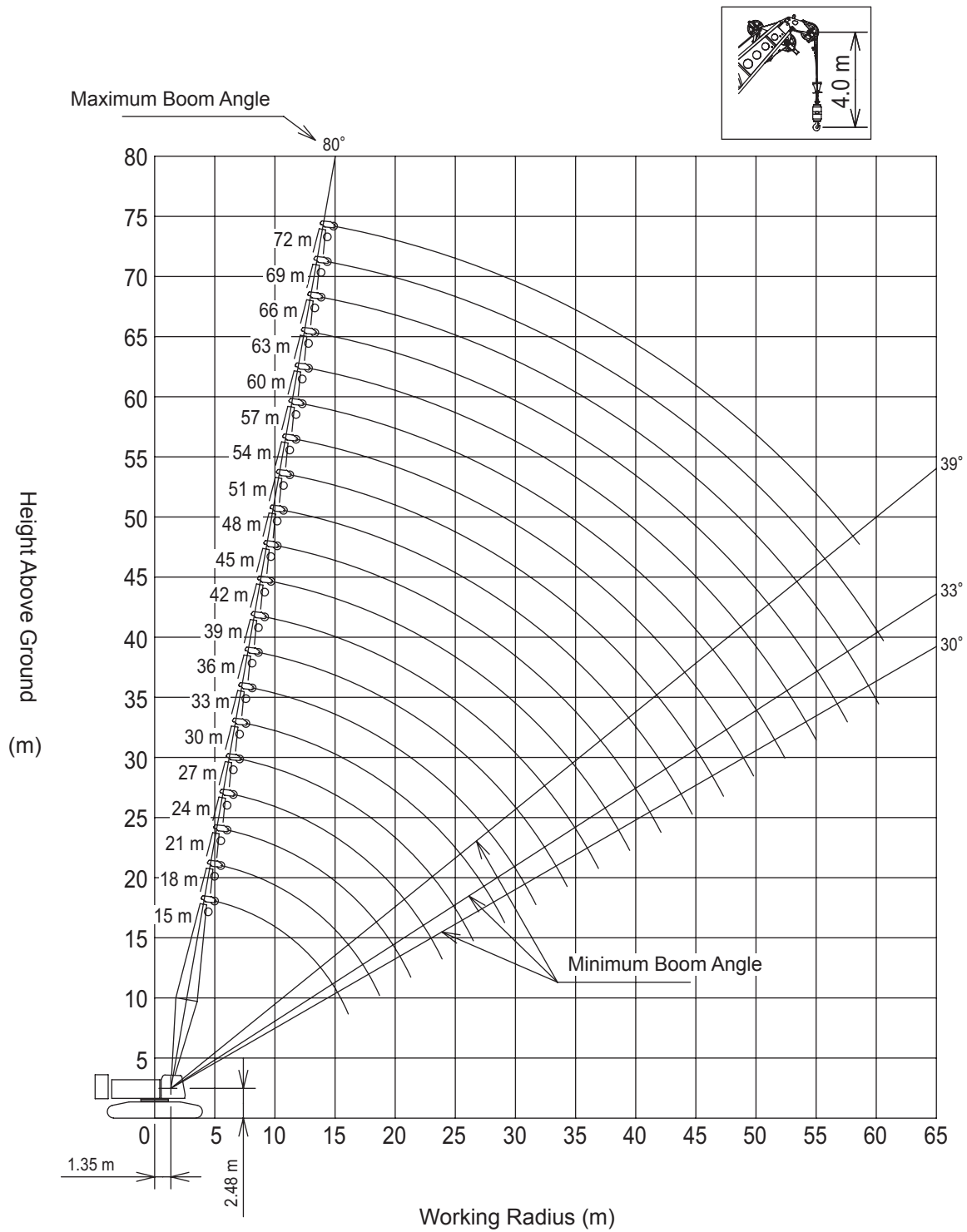

■ Crane Jib

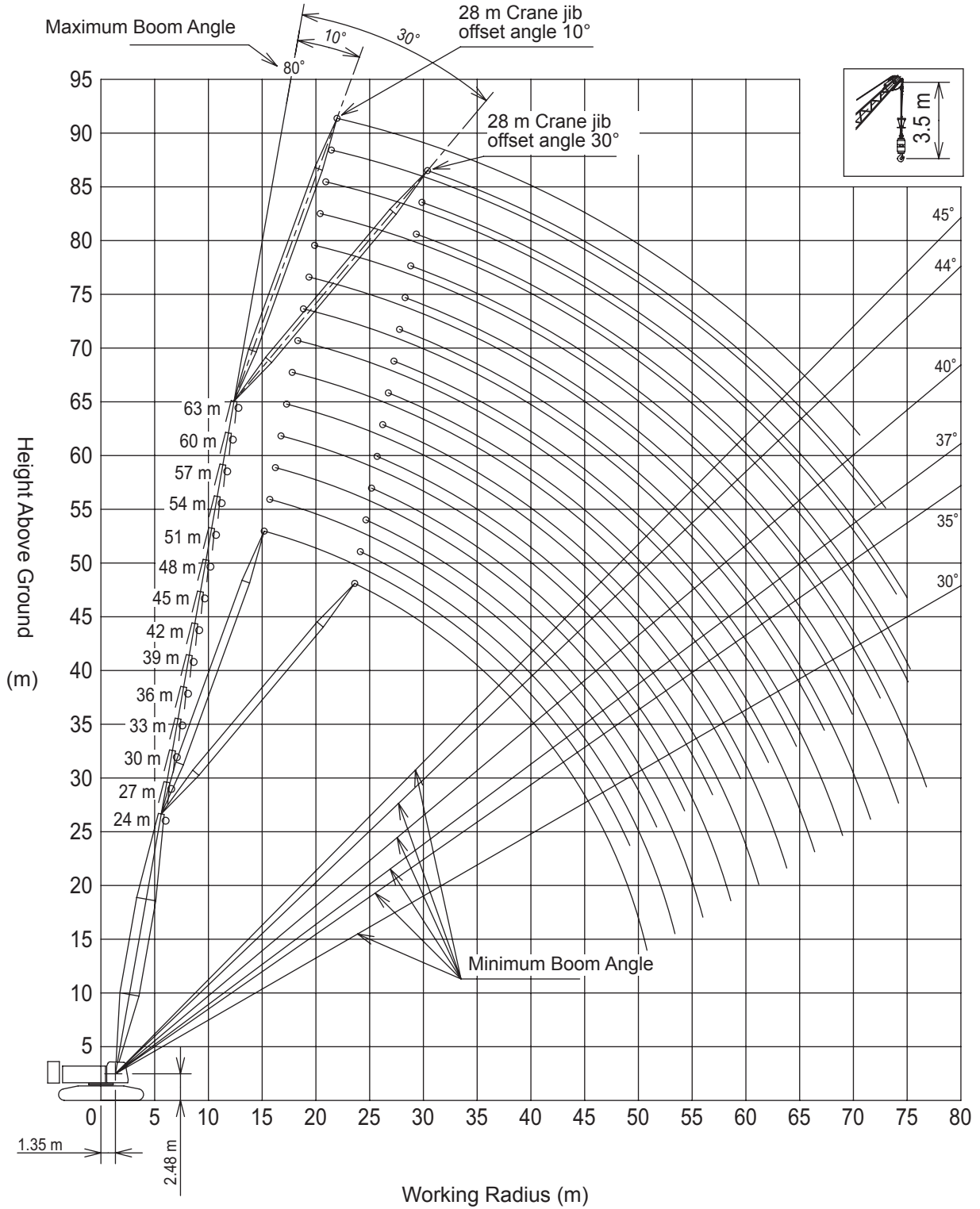

Gross Rated Load Table

Main Boom



Working Radius(m)	Boom length (m)											Working Radius(m)
	15	18	21	24	27	30	33	36	39	42	45	
4.5	150.0											4.5
5.0	135.2	132.0/5.2										5.0
5.5	123.4	123.3	108.0/5.7									5.5
6.0	113.5	113.4	108.0	96.0/6.3	84.0/6.8							6.0
7.0	97.7	97.6	97.8	96.0	84.0	72.0/7.4	72.0/7.9					7.0
8.0	85.6	85.5	85.7	85.6	84.0	72.0	72.0	60.0/8.5				8.0
9.0	73.4	73.5	73.9	73.9	73.9	72.0	72.0	60.0	60.0	48.0/9.6		9.0
10.0	62.8	62.9	63.3	63.3	63.2	63.2	63.1	60.0	60.0	48.0	48.0/10.1	10.0
12.0	48.4	48.5	48.8	48.8	48.7	48.7	48.6	48.5	48.4	48.0	47.7	12.0
14.0	39.1	39.2	39.5	39.5	39.4	39.4	39.2	39.1	39.0	39.0	38.8	14.0
16.0	37.3/14.5	32.6	33.0	33.0	32.8	32.8	32.7	32.6	32.4	32.4	32.2	16.0
18.0		29.8/17.1	28.1	28.1	28.0	28.0	27.8	27.7	27.6	27.5	27.3	18.0
20.0			24.9/19.7	24.4	24.3	24.2	24.1	24.0	23.8	23.8	23.6	20.0
22.0				21.5	21.3	21.3	21.2	21.0	20.9	20.8	20.6	22.0
24.0				21.1/22.3	19.0	18.9	18.8	18.6	18.5	18.4	18.2	24.0
26.0					18.0/24.9	16.9	16.8	16.6	16.5	16.4	16.2	26.0
28.0						15.6/27.5	15.1	15.0	14.8	14.7	14.5	28.0
30.0							13.7	13.5	13.4	13.3	13.1	30.0
32.0							13.6/30.1	12.3	12.2	12.1	11.8	32.0
34.0								11.9/32.7	11.1	11.0	10.8	34.0
36.0									10.5/35.3	10.0	9.8	36.0
38.0										9.2/37.9	9.0	38.0
40.0											8.2	40.0
42.0											8.1/40.5	42.0

Working Radius(m)	Boom length (m)											Working Radius(m)
	48	51	54	57	60	63	66	69	72	75		
10.0	36.0/10.6	36.0/11.2	36.0/11.7									10.0
12.0	36.0	36.0	36.0	36.0/12.3	24.0/12.9	24.0/13.5						12.0
14.0	36.0	36.0	36.0	35.7	24.0	24.0	24.0	24.0/14.5	23.6/15.1	21.0/15.6		14.0
16.0	32.2	32.0	31.8	31.5	24.0	24.0	24.0	24.0	23.2	20.9		16.0
18.0	27.3	27.1	26.9	26.8	24.0	24.0	24.0	24.0	22.3	20.1		18.0
20.0	23.5	23.4	23.2	23.0	23.0	22.7	22.4	21.9	21.3	19.3		20.0
22.0	20.6	20.4	20.2	20.0	20.0	19.8	19.6	19.3	18.8	18.3		22.0
24.0	18.1	18.0	17.8	17.6	17.6	17.4	17.2	17.0	16.7	16.3		24.0
26.0	16.1	16.0	15.8	15.6	15.5	15.3	15.2	15.0	14.8	14.5		26.0
28.0	14.4	14.3	14.1	13.9	13.9	13.6	13.5	13.3	13.1	12.9		28.0
30.0	13.0	12.8	12.6	12.5	12.4	12.2	12.0	11.9	11.6	11.5		30.0
32.0	11.8	11.6	11.4	11.2	11.2	10.9	10.8	10.6	10.4	10.2		32.0
34.0	10.7	10.5	10.3	10.1	10.1	9.9	9.7	9.5	9.3	9.1		34.0
36.0	9.7	9.6	9.4	9.2	9.1	8.9	8.7	8.5	8.3	8.2		36.0
38.0	8.9	8.7	8.5	8.3	8.3	8.0	7.9	7.7	7.5	7.3		38.0
40.0	8.1	8.0	7.8	7.6	7.5	7.3	7.1	6.9	6.7	6.5		40.0
42.0	7.5	7.3	7.1	6.9	6.8	6.6	6.4	6.3	6.0	5.9		42.0
44.0	7.1/43.1	6.7	6.5	6.3	6.2	6.0	5.8	5.6	5.4	5.2		44.0
46.0		6.2/45.7	5.9	5.8	5.6	5.4	5.3	5.1	4.9	4.7		46.0
48.0			5.4	5.3	5.1	4.9	4.8	4.6	4.4	4.2		48.0
50.0			5.4/48.3	4.8	4.7	4.5	4.3	4.1	3.9	3.7		50.0
52.0				4.6/50.9	4.2	4.0	3.9	3.7	3.5	3.3		52.0
54.0					4.0/53.2	3.6	3.5	3.3	3.1	2.9		54.0
56.0						3.3/55.8	3.1	2.9	2.7	2.5		56.0
58.0							2.8	2.6	2.4	2.2		58.0
60.0							2.7/58.4	2.3	2.1	1.9		60.0
62.0								2.1/61.0	1.8	1.6		62.0
64.0									1.6/63.6	1.4/63.3		64.0

- The rated loads are determined according to EN13000 rating on the condition that the machine is stationed on firm, level ground.
- The figures surrounded by bold lines are based on factors other than those which would cause a tipping condition.
- Be sure to attach the hanger sheaves block to the top boom when boom length is 15m.
- Be sure to remove the hanger sheaves block from the top boom when boom length is 18m or more.
- To calculate the maximum load that can actually be lifted, deduct weight of all lifting accessories, such as boom hook and jib hook, from figures shown above.
- Working radius is the horizontal distance from the slewing center to the center of gravity of a lifted load.
- The counterweight is 65.4ton. (Superstructure 56.4ton + Undercarriage 9.0 ton)
- Correlation between the number of reeved lines, maximum rated loads, hook weights are shown in the table below.

Hook Capacity (t)	Hook Weight (t)	Maximum rated loads (t)										
		11falls	10falls	9falls	8falls	7falls	6falls	5falls	4falls	3falls	2falls	1fall
150	2.35	150.0	135.0	121.5	108.0	94.5	81.0	67.5	54.0	40.5	27.0	
80	1.35						80.0	67.5	54.0	40.5	27.0	
35	0.90									35.0	27.0	
13.5	0.62											13.5

Aux. Sheave



Radius (m)	Boom length (m)											Radius (m)
	15	18	21	24	27	30	33	36	39	42	45	
5.6	13.5/5.6											5.6
6.0	13.5	13.5/6.3	13.5/6.9									6.0
7.0	13.5	13.5	13.5	13.5/7.4								7.0
8.0	13.5	13.5	13.5	13.5	13.5	13.5/8.5						8.0
9.0	13.5	13.5	13.5	13.5	13.5	13.5	13.5	13.5/9.6				9.0
10.0	13.5	13.5	13.5	13.5	13.5	13.5	13.5	13.5	13.5/10.1	13.5/10.7	13.5/11.2	10.0
12.0	13.5	13.5	13.5	13.5	13.5	13.5	13.5	13.5	13.5	13.5	13.5	12.0
14.0	13.5	13.5	13.5	13.5	13.5	13.5	13.5	13.5	13.5	13.5	13.5	14.0
16.0	13.5	13.5	13.5	13.5	13.5	13.5	13.5	13.5	13.5	13.5	13.5	16.0
18.0	13.5/16.1	13.5	13.5	13.5	13.5	13.5	13.5	13.5	13.5	13.5	13.5	18.0
20.0		13.5/18.7	13.5	13.5	13.5	13.5	13.5	13.5	13.5	13.5	13.5	20.0
22.0			13.5/21.3	13.5	13.5	13.5	13.5	13.5	13.5	13.5	13.5	22.0
24.0				13.5/23.9	13.5	13.5	13.5	13.5	13.5	13.5	13.5	24.0
26.0					13.5	13.5	13.5	13.5	13.5	13.5	13.5	26.0
28.0					13.5/26.5	13.5	13.5	13.5	13.5	13.5	13.5	28.0
30.0						13.5/29.1	13.5	13.4	13.2	13.1	12.9	30.0
32.0							12.5/31.7	12.1	12.0	11.9	11.6	32.0
34.0								11.0	10.9	10.8	10.5	34.0
36.0								10.9/34.3	9.9	9.8	9.6	36.0
38.0									9.6/36.9	9.0	8.8	38.0
40.0										8.4/39.5	8.0	40.0
42.0											7.3	42.0
44.0											7.3/42.1	44.0

Radius (m)	Boom length (m)									Radius (m)	
	48	51	54	57	60	63	66	69	72		
10.0	13.5/11.8									10.0	
12.0	13.5	13.5/12.3	13.5/12.9	13.5/13.4						12.0	
14.0	13.5	13.5	13.5	13.5	13.5	13.5/14.5	13.5/15.1	13.5/15.6		14.0	
16.0	13.5	13.5	13.5	13.5	13.5	13.5	13.5	13.5	13.5/16.2	16.0	
18.0	13.5	13.5	13.5	13.5	13.5	13.5	13.5	13.5	13.5	18.0	
20.0	13.5	13.5	13.5	13.5	13.5	13.5	13.5	13.5	13.5	20.0	
22.0	13.5	13.5	13.5	13.5	13.5	13.5	13.5	13.5	13.5	22.0	
24.0	13.5	13.5	13.5	13.5	13.5	13.5	13.5	13.5	13.5	24.0	
26.0	13.5	13.5	13.5	13.5	13.5	13.5	13.5	13.5	13.5	26.0	
28.0	13.5	13.5	13.5	13.5	13.5	13.4	13.3	13.1	12.8	28.0	
30.0	12.8	12.6	12.4	12.2	12.2	12.0	11.8	11.6	11.4	30.0	
32.0	11.6	11.4	11.2	11.0	10.9	10.7	10.5	10.4	10.1	32.0	
34.0	10.5	10.3	10.1	9.9	9.8	9.6	9.4	9.2	9.0	34.0	
36.0	9.5	9.3	9.1	8.9	8.9	8.6	8.5	8.3	8.1	36.0	
38.0	8.7	8.5	8.3	8.1	8.0	7.8	7.6	7.4	7.2	38.0	
40.0	7.9	7.7	7.5	7.3	7.2	7.0	6.8	6.7	6.4	40.0	
42.0	7.2	7.0	6.8	6.6	6.6	6.3	6.2	6.0	5.7	42.0	
44.0	6.6	6.4	6.2	6.0	5.9	5.7	5.5	5.3	5.1	44.0	
46.0	6.4/44.7	5.9	5.6	5.5	5.4	5.1	5.0	4.8	4.6	46.0	
48.0		5.6/47.3	5.1	5.0	4.9	4.6	4.5	4.3	4.0	48.0	
50.0			4.7/49.8	4.5	4.4	4.2	4.0	3.8	3.6	50.0	
52.0				4.1	4.0	3.7	3.6	3.4	3.1	52.0	
54.0					4.0/52.4	3.6	3.4	3.2	3.0	2.7	54.0
56.0						3.4/55.0	3.0	2.8	2.6	2.4	56.0
58.0							2.7/57.6	2.5	2.3	2.0	58.0
60.0								2.2	2.0	1.9/58.6	60.0
62.0								2.1/60.2	1.9/60.6		62.0

- The rated loads are determined according to EN13000 rating on the condition that the machine is stationed on firm, level ground.
- The figures surrounded by bold lines are based on factors other than those which would cause a tipping condition.
- To calculate the maximum load that can actually be lifted, deduct weight of all lifting accessories, such as boom hook and jib hook, from figures shown above.

Hook Capacity (t)	Hook Weight (t)
150	2.35
80	1.35
35	0.90
13.5	0.62

- Working radius is the horizontal distance from the slewing center to the center of gravity of a lifted load.
- The counterweight is 65.4ton. (Superstructure 56.4ton + Undercarriage 9.0 ton)

■ Main Boom with Aux. Sheave



Unit: ton

Radius (m)	Boom length (m)											Radius (m)
	15	18	21	24	27	30	33	36	39	42	45	
4.5	148.5											4.5
5.0	134.3	132.0 /5.2										5.0
5.5	122.6	122.4	108.0 /5.7									5.5
6.0	112.7	112.5	108.0	96.0 /6.3	84.0 /6.8							6.0
7.0	96.8	96.7	96.9	96.0	84.0	72.0 /7.4	72.0 /7.9					7.0
8.0	84.8	84.6	84.9	84.8	84.0	72.0	72.0	60.0 /8.5				8.0
9.0	73.0	73.1	73.5	73.5	73.4	72.0	72.0	60.0	60.0	48.0 /9.6		9.0
10.0	62.4	62.5	62.9	62.9	62.8	62.8	62.7	60.0	60.0	48.0	48.0 /10.1	10.0
12.0	48.1	48.1	48.4	48.4	48.3	48.3	48.2	48.1	48.0	47.9	47.0	12.0
14.0	38.8	38.8	39.1	39.1	39.0	39.0	38.8	38.7	38.6	38.5	38.3	14.0
16.0	36.9 /14.5	32.3	32.6	32.6	32.5	32.4	32.3	32.2	32.0	32.0	31.8	16.0
18.0		29.5 /17.1	27.8	27.8	27.6	27.6	27.4	27.3	27.2	27.1	26.9	18.0
20.0			24.6 /19.7	24.1	23.9	23.9	23.7	23.6	23.4	23.4	23.1	20.0
22.0				21.1	21.0	20.9	20.8	20.6	20.5	20.4	20.2	22.0
24.0				20.8 /22.3	18.6	18.5	18.4	18.2	18.1	18.0	17.8	24.0
26.0					17.7 /24.9	16.6	16.4	16.3	16.1	16.0	15.8	26.0
28.0						15.3 /27.5	14.8	14.6	14.4	14.3	14.1	28.0
30.0							13.4	13.2	13.0	12.9	12.7	30.0
32.0							13.3 /30.1	12.0	11.8	11.7	11.4	32.0
34.0								11.6 /32.7	10.7	10.6	10.4	34.0
36.0									10.1 /35.3	9.7	9.4	36.0
38.0										8.9 /37.9	8.6	38.0
40.0											7.9	40.0
42.0											7.7 /40.5	42.0

Unit: ton

Radius (m)	Boom length (m)										Radius (m)
	48	51	54	57	60	63	66	69	72		
10.0	36.0 /10.6	36.0 /11.2	36.0 /11.7								10.0
12.0	36.0	36.0	36.0	36.0 /12.3	24.0 /12.9	24.0 /13.5					12.0
14.0	36.0	36.0	36.0	34.6	24.0	24.0	24.0	24.0 /14.5	22.5 /15.1		14.0
16.0	31.7	31.5	31.3	30.8	24.0	24.0	24.0	24.0	22.0		16.0
18.0	26.8	26.7	26.5	26.3	24.0	23.9	24.0	22.9	21.2		18.0
20.0	23.1	22.9	22.7	22.5	22.5	21.7	21.7	21.1	20.3		20.0
22.0	20.1	19.9	19.7	19.6	19.5	19.3	19.1	18.6	18.1		22.0
24.0	17.7	17.5	17.3	17.1	17.1	16.9	16.7	16.5	16.0		24.0
26.0	15.7	15.5	15.3	15.1	15.1	14.9	14.7	14.5	14.2		26.0
28.0	14.0	13.9	13.6	13.5	13.4	13.2	13.0	12.8	12.6		28.0
30.0	12.6	12.4	12.2	12.0	11.9	11.7	11.5	11.4	11.1		30.0
32.0	11.4	11.2	11.0	10.8	10.7	10.5	10.3	10.1	9.9		32.0
34.0	10.3	10.1	9.9	9.7	9.6	9.4	9.2	9.0	8.8		34.0
36.0	9.3	9.2	8.9	8.7	8.7	8.4	8.3	8.1	7.8		36.0
38.0	8.5	8.3	8.1	7.9	7.8	7.6	7.4	7.2	7.0		38.0
40.0	7.8	7.6	7.3	7.2	7.1	6.8	6.6	6.5	6.2		40.0
42.0	7.1	6.9	6.7	6.5	6.4	6.2	6.0	5.8	5.5		42.0
44.0	6.8 /43.1	6.3	6.1	5.9	5.8	5.5	5.4	5.2	4.9		44.0
46.0		5.9 /45.7	5.5	5.3	5.2	5.0	4.8	4.6	4.4		46.0
48.0			5.0	4.9	4.7	4.5	4.3	4.1	3.9		48.0
50.0			5.0 /48.3	4.4	4.3	4.0	3.8	3.6	3.4		50.0
52.0				4.2 /50.9	3.8	3.6	3.4	3.2	3.0		52.0
54.0					3.6 /53.2	3.2	3.0	2.8	2.6		54.0
56.0						2.9 /55.8	2.7	2.5	2.3		56.0
58.0							2.4	2.2	1.9		58.0
60.0							2.3 /58.4	1.9			60.0

- The rated loads are determined according to EN13000 rating on the condition that the machine is stationed on firm, level ground.
- The figures surrounded by bold lines are based on factors other than those which would cause a tipping condition.
- Be sure to attach the hanger sheaves block to the top boom when boom length is 15m.
- Be sure to remove the hanger sheaves block from the top boom when boom length is 18m or more.
- To calculate the maximum load that can actually be lifted, deduct weight of all lifting accessories, such as boom hook and jib hook, from figures shown above.
- Working radius is the horizontal distance from the slewing center to the center of gravity of a lifted load.
- The counterweight is 65.4ton. (Superstructure 56.4ton + Undercarriage 9.0 ton)
- Correlation between the number of reeved lines, maximum rated loads, hook weights are shown in the table below.

Hook Capacity (t)	Hook Weight (t)	Maximum rated loads (t)										
		11falls	10falls	9falls	8falls	7falls	6falls	5falls	4falls	3falls	2falls	1fall
150	2.35	150.0	135.0	121.5	108.0	94.5	81.0	67.5	54.0	40.5	27.0	
80	1.35						80.0	67.5	54.0	40.5	27.0	
35	0.90									35.0	27.0	
13.5	0.62											13.5

Crane Jib



Unit: ton

Boom length (m)	24								Boom length (m)
Jib length (m)	10		16		22		28		Jib length (m)
Offset angle (deg) Radius (m)	10	30	10	30	10	30	10	30	Offset angle (deg) Radius (m)
9.7	12.0								9.7
10.0	12.0		12.0/11.8						10.0
12.0	12.0	12.0/12.6	12.0		8.8/13.9				12.0
14.0	12.0	12.0	12.0		8.8				14.0
16.0	12.0	12.0	12.0	9.0/16.5	8.8		5.4		16.0
18.0	12.0	12.0	12.0	9.0	8.6		5.1		18.0
20.0	12.0	12.0	12.0	9.0	8.3	6.4/20.4	4.8		20.0
22.0	12.0	11.7	12.0	9.0	7.9	6.4	4.5		22.0
24.0	12.0	11.2	12.0	9.0	7.6	6.4	4.3	3.4/24.3	24.0
26.0	12.0	10.8	12.0	8.7	7.3	6.4	4.1	3.4	26.0
28.0	12.0	10.4	11.9	8.3	7.0	6.4	3.9	3.3	28.0
30.0	12.0	10.2	11.1	8.0	6.8	6.2	3.7	3.1	30.0
32.0	12.0	10.0	10.4	7.7	6.6	5.9	3.6	3.0	32.0
34.0	12.0/32.2	9.9/32.8	9.8	7.5	6.4	5.7	3.4	2.9	34.0
36.0			9.3	7.3	6.2	5.4	3.3	2.9	36.0
38.0			8.9/37.9	7.2	6.1	5.3	3.2	2.8	38.0
40.0				7.2/38.8	5.9	5.1	3.1	2.7	40.0
42.0					5.8	5.0	3.0	2.7	42.0
44.0					5.8/43.5	4.9	2.9	2.6	44.0
46.0						4.9/44.8	2.8	2.6	46.0
48.0							2.7	2.6	48.0
50.0							2.7/49.2	2.6	50.0
52.0								2.6/50.8	52.0

Unit: ton

Boom length (m)	27								Boom length (m)
Jib length (m)	10		16		22		28		Jib length (m)
Offset angle (deg) Radius (m)	10	30	10	30	10	30	10	30	Offset angle (deg) Radius (m)
10.0	12.0/10.2								10.0
12.0	12.0	12.0/13.2	12.0/12.3						12.0
14.0	12.0	12.0	12.0		8.8/14.4				14.0
16.0	12.0	12.0	12.0	9.0/17.1	8.8		5.4/16.5		16.0
18.0	12.0	12.0	12.0	9.0	8.8		5.2		18.0
20.0	12.0	12.0	12.0	9.0	8.4	6.4/21.0	4.9		20.0
22.0	12.0	12.0	12.0	9.0	8.1	6.4	4.6		22.0
24.0	12.0	11.5	12.0	9.0	7.8	6.4	4.4	3.4/24.9	24.0
26.0	12.0	11.1	12.0	8.9	7.5	6.4	4.2	3.4	26.0
28.0	12.0	10.7	12.0	8.5	7.2	6.4	4.0	3.3	28.0
30.0	12.0	10.4	11.8	8.2	7.0	6.3	3.8	3.2	30.0
32.0	12.0	10.2	11.1	7.9	6.7	6.1	3.7	3.1	32.0
34.0	12.0	10.0	10.4	7.7	6.5	5.8	3.5	3.0	34.0
36.0	11.6/34.8	9.9/35.4	9.9	7.5	6.4	5.6	3.4	2.9	36.0
38.0			9.4	7.3	6.2	5.4	3.3	2.8	38.0
40.0			9.0	7.2	6.1	5.2	3.2	2.8	40.0
42.0			8.9/40.5	7.2/41.4	5.9	5.1	3.1	2.7	42.0
44.0					5.9	5.0	3.0	2.7	44.0
46.0					5.8	4.9	2.9	2.6	46.0
48.0					5.8/46.1	4.8/47.4	2.8	2.6	48.0
50.0							2.8	2.6	50.0
52.0							2.7/51.7	2.6	52.0
54.0								2.6/53.4	54.0

- The rated loads are determined according to EN13000 rating on the condition that the machine is stationed on firm, level ground.
- The figures surrounded by bold lines are based on factors other than those which would cause a tipping condition.
- To calculate the maximum load that can actually be lifted, deduct weight of all lifting accessories, such as boom hook and jib hook, from figures shown above.

Hook Capacity (t)	Hook Weight (t)
150	2.35
80	1.35
35	0.90
13.5	0.62

- Working radius is the horizontal distance from the slewing center to the center of gravity of a lifted load.
- The offset angles shown are of jib boom offset angle against the main boom, under load.
- The counterweight is 65.4ton. (Superstructure 56.4ton + Undercarriage 9.0 ton)

■ Crane Jib



Unit: ton

Boom length (m)	30								Boom length (m)
Jib length (m)	10		16		22		28		Jib length (m)
Offset angle (deg) Radius (m)	10	30	10	30	10	30	10	30	Offset angle (deg) Radius (m)
10.7	12.0								10.7
12.0	12.0	12.0/13.7	12.0/12.8						12.0
14.0	12.0	12.0	12.0		8.8/15.0				14.0
16.0	12.0	12.0	12.0	9.0/17.6	8.8		5.4/17.1		16.0
18.0	12.0	12.0	12.0	9.0	8.8		5.2		18.0
20.0	12.0	12.0	12.0	9.0	8.6	6.4/21.5	5.0		20.0
22.0	12.0	12.0	12.0	9.0	8.2	6.4	4.7		22.0
24.0	12.0	11.8	12.0	9.0	7.9	6.4	4.5	3.4/25.4	24.0
26.0	12.0	11.4	12.0	9.0	7.6	6.4	4.3	3.4	26.0
28.0	12.0	11.0	12.0	8.7	7.4	6.4	4.1	3.3	28.0
30.0	12.0	10.7	12.0	8.4	7.1	6.4	3.9	3.2	30.0
32.0	12.0	10.4	11.7	8.1	6.9	6.2	3.8	3.1	32.0
34.0	11.9	10.2	11.0	7.9	6.7	6.0	3.6	3.0	34.0
36.0	10.9	10.0	10.5	7.7	6.5	5.8	3.5	2.9	36.0
38.0	10.3/37.4	9.9	9.9	7.5	6.3	5.6	3.4	2.9	38.0
40.0			9.5	7.3	6.2	5.4	3.2	2.8	40.0
42.0			9.0	7.2	6.1	5.2	3.1	2.7	42.0
44.0			8.6/43.1	7.1	6.0	5.1	3.0	2.7	44.0
46.0					5.9	5.0	3.0	2.7	46.0
48.0					5.8	4.9	2.9	2.6	48.0
50.0					5.8/48.7	4.8	2.8	2.6	50.0
52.0							2.8	2.6	52.0
54.0							2.7	2.6	54.0
56.0							2.7/54.3	2.6	56.0

Unit: ton

Boom length (m)	33								Boom length (m)
Jib length (m)	10		16		22		28		Jib length (m)
Offset angle (deg) Radius (m)	10	30	10	30	10	30	10	30	Offset angle (deg) Radius (m)
10.7	12.0/11.3								10.7
12.0	12.0		12.0/13.4						12.0
14.0	12.0	12.0/14.3	12.0		8.8/15.5				14.0
16.0	12.0	12.0	12.0		8.8		5.4/17.6		16.0
18.0	12.0	12.0	12.0	9.0/18.2	8.8		5.3		18.0
20.0	12.0	12.0	12.0	9.0	8.7		5.0		20.0
22.0	12.0	12.0	12.0	9.0	8.4	6.4/22.1	4.8		22.0
24.0	12.0	12.0	12.0	9.0	8.1	6.4	4.6		24.0
26.0	12.0	11.7	12.0	9.0	7.8	6.4	4.4	3.4	26.0
28.0	12.0	11.3	12.0	8.9	7.5	6.4	4.2	3.4	28.0
30.0	12.0	11.0	12.0	8.6	7.3	6.4	4.0	3.2	30.0
32.0	12.0	10.7	12.0	8.3	7.0	6.4	3.9	3.1	32.0
34.0	11.7	10.4	11.6	8.1	6.8	6.1	3.7	3.1	34.0
36.0	10.7	10.2	11.0	7.9	6.7	5.9	3.6	3.0	36.0
38.0	9.9	10.0	10.2	7.7	6.5	5.7	3.5	2.9	38.0
40.0	9.1	9.2	9.5	7.5	6.3	5.5	3.3	2.8	40.0
42.0		9.0/40.6	8.8	7.3	6.2	5.3	3.2	2.8	42.0
44.0			8.1	7.2	6.1	5.2	3.1	2.7	44.0
46.0			7.7/45.7	7.1	6.0	5.1	3.0	2.7	46.0
48.0				7.1/46.6	5.9	5.0	3.0	2.7	48.0
50.0					5.8	4.9	2.9	2.6	50.0
52.0					5.8/51.3	4.8	2.8	2.6	52.0
54.0						4.8/52.6	2.8	2.6	54.0
56.0							2.7	2.6	56.0
58.0							2.7/56.9	2.6	58.0
60.0								2.6/58.6	60.0

■ Crane Jib



Unit: ton

Boom length (m)	36								Boom length (m)
Jib length (m)	10		16		22		28		Jib length (m)
Offset angle (deg) Radius (m)	10	30	10	30	10	30	10	30	Offset angle (deg) Radius (m)
11.8	12.0								11.8
12.0	12.0		12.0/13.9						12.0
14.0	12.0	12.0/14.8	12.0						14.0
16.0	12.0	12.0	12.0		8.8				16.0
18.0	12.0	12.0	12.0	9.0/18.7	8.8		5.4/18.1		18.0
20.0	12.0	12.0	12.0	9.0	8.8		5.1		20.0
22.0	12.0	12.0	12.0	9.0	8.5	6.4/22.6	4.9		22.0
24.0	12.0	12.0	12.0	9.0	8.2	6.4	4.7		24.0
26.0	12.0	11.9	12.0	9.0	7.9	6.4	4.5	3.4/26.5	26.0
28.0	12.0	11.5	12.0	9.0	7.7	6.4	4.3	3.4	28.0
30.0	12.0	11.2	12.0	8.8	7.4	6.4	4.1	3.3	30.0
32.0	12.0	10.9	12.0	8.5	7.2	6.4	4.0	3.2	32.0
34.0	11.5	10.6	11.9	8.3	7.0	6.2	3.8	3.1	34.0
36.0	10.5	10.4	10.9	8.0	6.8	6.0	3.7	3.0	36.0
38.0	9.7	9.8	10.0	7.8	6.6	5.8	3.5	2.9	38.0
40.0	8.9	9.0	9.3	7.6	6.5	5.6	3.4	2.9	40.0
42.0	8.2	8.3	8.6	7.5	6.3	5.5	3.3	2.8	42.0
44.0	8.0/42.6	7.9/43.2	7.9	7.3	6.2	5.3	3.2	2.8	44.0
46.0			7.4	7.2	6.1	5.2	3.1	2.7	46.0
48.0			6.9	7.0	6.0	5.1	3.0	2.7	48.0
50.0			6.8/48.3	6.7/49.2	5.9	5.0	3.0	2.6	50.0
52.0					5.8	4.9	2.9	2.6	52.0
54.0					5.8/53.9	4.8	2.8	2.6	54.0
56.0						4.8/55.2	2.8	2.6	56.0
58.0							2.7	2.6	58.0
60.0							2.7/59.5	2.6	60.0
62.0								2.6/61.2	62.0

Unit: ton

Boom length (m)	39								Boom length (m)
Jib length (m)	10		16		22		28		Jib length (m)
Offset angle (deg) Radius (m)	10	30	10	30	10	30	10	30	Offset angle (deg) Radius (m)
12.0	12.0/12.4								12.0
14.0	12.0	12.0/15.4	12.0/14.5						14.0
16.0	12.0	12.0	12.0		8.8/16.6				16.0
18.0	12.0	12.0	12.0	9.0/19.3	8.8		5.3/18.7		18.0
20.0	12.0	12.0	12.0	9.0	8.8		5.2		20.0
22.0	12.0	12.0	12.0	9.0	8.6	6.4/23.2	5.0		22.0
24.0	12.0	12.0	12.0	9.0	8.3	6.4	4.7		24.0
26.0	12.0	12.0	12.0	9.0	8.0	6.4	4.5	3.4/27.1	26.0
28.0	12.0	11.8	12.0	9.0	7.8	6.4	4.4	3.4	28.0
30.0	12.0	11.4	12.0	8.9	7.6	6.4	4.2	3.3	30.0
32.0	12.0	11.1	12.0	8.7	7.3	6.4	4.0	3.2	32.0
34.0	11.3	10.8	11.7	8.4	7.1	6.4	3.9	3.1	34.0
36.0	10.3	10.6	10.7	8.2	6.9	6.1	3.8	3.0	36.0
38.0	9.5	9.7	9.8	8.0	6.8	5.9	3.6	3.0	38.0
40.0	8.7	8.9	9.1	7.8	6.6	5.8	3.5	2.9	40.0
42.0	8.1	8.2	8.4	7.6	6.4	5.6	3.4	2.8	42.0
44.0	7.4	7.5	7.8	7.5	6.3	5.4	3.3	2.8	44.0
46.0	7.1/45.2	7.0/45.8	7.2	7.3	6.2	5.3	3.2	2.7	46.0
48.0			6.7	6.8	6.1	5.2	3.1	2.7	48.0
50.0			6.2	6.3	6.0	5.1	3.0	2.7	50.0
52.0			6.0/50.9	5.9/51.8	5.9	5.0	3.0	2.6	52.0
54.0					5.6	4.9	2.9	2.6	54.0
56.0					5.2	4.8	2.8	2.6	56.0
58.0					5.2/56.5	4.8/57.8	2.8	2.6	58.0
60.0							2.7	2.6	60.0
62.0							2.7	2.6	62.0
64.0							2.7/62.1	2.6/63.8	64.0

■ Crane Jib



Unit: ton

Boom length (m)	42								Boom length (m)
Jib length (m)	10		16		22		28		Jib length (m)
Offset angle (deg) Radius (m)	10	30	10	30	10	30	10	30	Offset angle (deg) Radius (m)
12.9	12.0								12.9
14.0	12.0	12.0 /15.9	12.0 /15.0						14.0
16.0	12.0	12.0	12.0		8.8 /17.1				16.0
18.0	12.0	12.0	12.0	9.0 /19.8	8.8		5.3 /19.2		18.0
20.0	12.0	12.0	12.0	9.0	8.8		5.2		20.0
22.0	12.0	12.0	12.0	9.0	8.7	6.4 /23.7	5.0		22.0
24.0	12.0	12.0	12.0	9.0	8.4	6.4	4.8		24.0
26.0	12.0	12.0	12.0	9.0	8.2	6.4	4.6	3.4 /27.6	26.0
28.0	12.0	12.0	12.0	9.0	7.9	6.4	4.4	3.4	28.0
30.0	12.0	11.6	12.0	9.0	7.7	6.4	4.3	3.3	30.0
32.0	12.0	11.3	12.0	8.8	7.5	6.4	4.1	3.2	32.0
34.0	11.2	11.1	11.6	8.6	7.3	6.4	4.0	3.1	34.0
36.0	10.2	10.5	10.6	8.3	7.1	6.3	3.8	3.1	36.0
38.0	9.4	9.6	9.7	8.1	6.9	6.1	3.7	3.0	38.0
40.0	8.6	8.8	8.9	7.9	6.7	5.9	3.6	2.9	40.0
42.0	7.9	8.1	8.2	7.8	6.6	5.7	3.5	2.9	42.0
44.0	7.3	7.4	7.6	7.6	6.4	5.5	3.4	2.8	44.0
46.0	6.7	6.8	7.0	7.3	6.3	5.4	3.3	2.8	46.0
48.0	6.3 /47.8	6.3	6.5	6.7	6.2	5.3	3.2	2.7	48.0
50.0		6.2 /48.4	6.1	6.2	6.1	5.2	3.1	2.7	50.0
52.0			5.6	5.7	5.9	5.1	3.0	2.6	52.0
54.0			5.3 /53.5	5.3	5.5	5.0	2.9	2.6	54.0
56.0				5.2 /54.4	5.1	4.9	2.9	2.6	56.0
58.0					4.7	4.8	2.8	2.6	58.0
60.0					4.6 /59.1	4.5	2.8	2.6	60.0
62.0						4.4 /60.4	2.7	2.6	62.0
64.0							2.7	2.6	64.0
66.0							2.7 /64.7	2.6	66.0
68.0								2.6 /66.4	68.0

Unit: ton

Boom length (m)	45								Boom length (m)
Jib length (m)	10		16		22		28		Jib length (m)
Offset angle (deg) Radius (m)	10	30	10	30	10	30	10	30	Offset angle (deg) Radius (m)
12.9	12.0 /13.5								12.9
14.0	12.0		12.0 /15.6						14.0
16.0	12.0	12.0 /16.5	12.0		8.8 /17.7				16.0
18.0	12.0	12.0	12.0		8.8		5.3 /19.8		18.0
20.0	12.0	12.0	12.0	9.0 /20.4	8.8		5.3		20.0
22.0	12.0	12.0	12.0	9.0	8.8		5.1		22.0
24.0	12.0	12.0	12.0	9.0	8.5	6.4 /24.3	4.9		24.0
26.0	12.0	12.0	12.0	9.0	8.3	6.4	4.7		26.0
28.0	12.0	12.0	12.0	9.0	8.0	6.4	4.5	3.4 /28.2	28.0
30.0	12.0	11.8	12.0	9.0	7.8	6.4	4.3	3.3	30.0
32.0	12.0	11.5	12.0	9.0	7.6	6.4	4.2	3.3	32.0
34.0	11.0	11.3	11.3	8.7	7.4	6.4	4.0	3.2	34.0
36.0	10.0	10.3	10.4	8.5	7.2	6.4	3.9	3.1	36.0
38.0	9.1	9.4	9.5	8.3	7.0	6.2	3.8	3.0	38.0
40.0	8.4	8.6	8.7	8.1	6.8	6.0	3.7	3.0	40.0
42.0	7.7	7.9	8.0	7.9	6.7	5.8	3.5	2.9	42.0
44.0	7.1	7.2	7.4	7.7	6.5	5.7	3.4	2.8	44.0
46.0	6.5	6.6	6.8	7.1	6.4	5.5	3.3	2.8	46.0
48.0	6.0	6.1	6.3	6.5	6.3	5.4	3.3	2.7	48.0
50.0	5.5	5.6	5.8	6.0	6.1	5.3	3.2	2.7	50.0
52.0	5.4 /50.4	5.4 /51.0	5.4	5.6	5.6	5.1	3.1	2.7	52.0
54.0			5.0	5.1	5.2	5.1	3.0	2.6	54.0
56.0			4.6	4.7	4.9	5.0	2.9	2.6	56.0
58.0			4.6 /56.1	4.5 /57.0	4.5	4.7	2.9	2.6	58.0
60.0					4.2	4.3	2.8	2.6	60.0
62.0					3.9 /61.7	4.0	2.8	2.6	62.0
64.0						3.8 /63.0	2.7	2.6	64.0
66.0							2.7	2.6	66.0
68.0							2.7 /67.3	2.6	68.0
70.0								2.6 /69.0	70.0

■ Crane Jib



Unit: ton

Boom length (m)	48								Boom length (m)
Jib length (m)	10		16		22		28		Jib length (m)
Offset angle (deg) Radius (m)	10	30	10	30	10	30	10	30	Offset angle (deg) Radius (m)
14.0	12.0								14.0
16.0	12.0	12.0/17.0	12.0/16.1						16.0
18.0	12.0	12.0	12.0		8.8/18.2				18.0
20.0	12.0	12.0	12.0	9.0/20.9	8.8		5.3/20.3		20.0
22.0	12.0	12.0	12.0	9.0	8.8		5.1		22.0
24.0	12.0	12.0	12.0	9.0	8.6	6.4/24.8	4.9		24.0
26.0	12.0	12.0	12.0	9.0	8.4	6.4	4.8		26.0
28.0	12.0	12.0	12.0	9.0	8.1	6.4	4.6	3.4/28.7	28.0
30.0	12.0	12.0	12.0	9.0	7.9	6.4	4.4	3.4	30.0
32.0	11.9	11.7	12.0	9.0	7.7	6.4	4.3	3.3	32.0
34.0	10.8	11.2	11.2	8.8	7.5	6.4	4.1	3.2	34.0
36.0	9.9	10.2	10.2	8.6	7.3	6.4	4.0	3.1	36.0
38.0	9.0	9.3	9.4	8.4	7.1	6.3	3.9	3.1	38.0
40.0	8.2	8.5	8.6	8.2	7.0	6.1	3.7	3.0	40.0
42.0	7.6	7.8	7.9	8.0	6.8	5.9	3.6	2.9	42.0
44.0	6.9	7.1	7.3	7.6	6.7	5.8	3.5	2.9	44.0
46.0	6.4	6.5	6.7	7.0	6.5	5.6	3.4	2.8	46.0
48.0	5.9	6.0	6.2	6.4	6.4	5.5	3.3	2.8	48.0
50.0	5.4	5.5	5.7	5.9	5.9	5.4	3.2	2.7	50.0
52.0	5.0	5.0	5.3	5.5	5.5	5.2	3.2	2.7	52.0
54.0	4.8/53.0	4.7/53.6	4.9	5.0	5.1	5.1	3.1	2.7	54.0
56.0			4.5	4.6	4.7	5.0	3.0	2.6	56.0
58.0			4.1	4.2	4.4	4.6	2.9	2.6	58.0
60.0			4.0/58.7	4.0/59.6	4.0	4.2	2.9	2.6	60.0
62.0					3.7	3.9	2.8	2.6	62.0
64.0					3.5	3.6	2.8	2.6	64.0
66.0					3.4/64.3	3.3/65.6	2.7	2.6	66.0
68.0							2.7	2.6	68.0
70.0							2.7/69.9	2.6	70.0
72.0								2.6/71.6	72.0

Unit: ton

Boom length (m)	51								Boom length (m)
Jib length (m)	10		16		22		28		Jib length (m)
Offset angle (deg) Radius (m)	10	30	10	30	10	30	10	30	Offset angle (deg) Radius (m)
14.0	12.0/14.6								14.0
16.0	12.0	12.0/17.6	12.0/16.7						16.0
18.0	12.0	12.0	12.0		8.8/18.8				18.0
20.0	12.0	12.0	12.0	9.0/21.5	8.8		5.3/20.9		20.0
22.0	12.0	12.0	12.0	9.0	8.8		5.2		22.0
24.0	12.0	12.0	12.0	9.0	8.7	6.4/25.4	5.0		24.0
26.0	12.0	12.0	12.0	9.0	8.5	6.4	4.8		26.0
28.0	12.0	12.0	12.0	9.0	8.2	6.4	4.6	3.4/29.3	28.0
30.0	12.0	12.0	12.0	9.0	8.0	6.4	4.5	3.4	30.0
32.0	11.8	11.9	12.0	9.0	7.8	6.4	4.3	3.3	32.0
34.0	10.7	11.0	11.0	9.0	7.6	6.4	4.2	3.2	34.0
36.0	9.7	10.0	10.1	8.7	7.4	6.4	4.0	3.1	36.0
38.0	8.8	9.1	9.2	8.5	7.2	6.4	3.9	3.1	38.0
40.0	8.1	8.3	8.4	8.3	7.1	6.2	3.8	3.0	40.0
42.0	7.4	7.6	7.7	8.1	6.9	6.0	3.7	2.9	42.0
44.0	6.7	6.9	7.1	7.4	6.8	5.9	3.6	2.9	44.0
46.0	6.2	6.3	6.5	6.8	6.6	5.7	3.5	2.8	46.0
48.0	5.7	5.8	6.0	6.3	6.2	5.6	3.4	2.8	48.0
50.0	5.2	5.3	5.5	5.8	5.8	5.4	3.3	2.7	50.0
52.0	4.8	4.9	5.1	5.3	5.3	5.3	3.2	2.7	52.0
54.0	4.4	4.4	4.7	4.9	4.9	5.2	3.1	2.7	54.0
56.0	4.1/55.6	4.1	4.3	4.5	4.5	4.8	3.1	2.6	56.0
58.0		4.0/56.2	4.0	4.1	4.2	4.5	3.0	2.6	58.0
60.0			3.6	3.7	3.9	4.1	2.9	2.6	60.0
62.0			3.4/61.3	3.4	3.6	3.8	2.9	2.6	62.0
64.0				3.4/62.2	3.3	3.4	2.8	2.6	64.0
66.0					3.0	3.1	2.8	2.6	66.0
68.0					2.9/66.9	2.9	2.7	2.6	68.0
70.0							2.8/68.2	2.7	70.0
72.0								2.5	72.0
74.0								2.4/72.5	74.0
76.0								2.4/74.2	76.0

■ Crane Jib



Unit: ton

Boom length (m)	54								Boom length (m)
Jib length (m)	10		16		22		28		Jib length (m)
Offset angle (deg) Radius (m)	10	30	10	30	10	30	10	30	Offset angle (deg) Radius (m)
15.1	12.0								15.1
16.0	12.0		12.0/17.2						16.0
18.0	12.0	12.0/18.1	12.0		8.8/19.3				18.0
20.0	12.0	12.0	12.0		8.8		5.3/21.4		20.0
22.0	12.0	12.0	12.0	9.0	8.8		5.2		22.0
24.0	12.0	12.0	12.0	9.0	8.8	6.4/25.9	5.0		24.0
26.0	12.0	12.0	12.0	9.0	8.6	6.4	4.9		26.0
28.0	12.0	12.0	12.0	9.0	8.3	6.4	4.7	3.4/29.8	28.0
30.0	12.0	12.0	12.0	9.0	8.1	6.4	4.5	3.4	30.0
32.0	11.5	12.0	11.9	9.0	7.9	6.4	4.4	3.3	32.0
34.0	10.4	10.8	10.8	9.0	7.7	6.4	4.2	3.2	34.0
36.0	9.5	9.8	9.8	8.9	7.5	6.4	4.1	3.2	36.0
38.0	8.6	8.9	9.0	8.7	7.3	6.4	4.0	3.1	38.0
40.0	7.8	8.1	8.2	8.5	7.2	6.3	3.9	3.0	40.0
42.0	7.1	7.4	7.5	7.9	7.0	6.1	3.8	3.0	42.0
44.0	6.5	6.7	6.9	7.3	6.9	5.9	3.6	2.9	44.0
46.0	5.9	6.1	6.3	6.6	6.6	5.8	3.5	2.9	46.0
48.0	5.4	5.6	5.8	6.1	6.0	5.7	3.5	2.8	48.0
50.0	5.0	5.1	5.3	5.6	5.5	5.5	3.4	2.8	50.0
52.0	4.5	4.7	4.8	5.1	5.1	5.4	3.3	2.7	52.0
54.0	4.1	4.2	4.4	4.7	4.7	5.1	3.2	2.7	54.0
56.0	3.8	3.8	4.1	4.3	4.3	4.7	3.1	2.7	56.0
58.0	3.4	3.5	3.7	3.9	4.0	4.3	3.1	2.6	58.0
60.0	3.4/58.2	3.3/58.8	3.4	3.5	3.6	3.9	3.0	2.6	60.0
62.0			3.1	3.2	3.3	3.6	2.9	2.6	62.0
64.0			2.8/63.9	2.9	3.1	3.3	2.9	2.6	64.0
66.0				2.8/64.8	2.8	3.0	2.8	2.6	66.0
68.0					2.5	2.7	2.7	2.6	68.0
70.0					2.4/69.5	2.4	2.5	2.6	70.0
72.0						2.3/70.8	2.3	2.5	72.0
74.0							2.1	2.2	74.0
76.0							2.0/75.1	2.0	76.0
78.0								1.9/76.8	78.0

Unit: ton

Boom length (m)	57								Boom length (m)
Jib length (m)	10		16		22		28		Jib length (m)
Offset angle (deg) Radius (m)	10	30	10	30	10	30	10	30	Offset angle (deg) Radius (m)
15.1	12.0/15.7								15.1
16.0	12.0		12.0/17.8						16.0
18.0	12.0	12.0/18.7	12.0		8.8/19.9				18.0
20.0	12.0	12.0	12.0		8.8				20.0
22.0	12.0	12.0	12.0	9.0/22.6	8.8		5.3		22.0
24.0	12.0	12.0	12.0	9.0	8.8		5.1		24.0
26.0	12.0	12.0	12.0	9.0	8.7	6.4/26.5	4.9		26.0
28.0	12.0	12.0	12.0	9.0	8.4	6.4	4.8		28.0
30.0	12.0	12.0	12.0	9.0	8.2	6.4	4.6	3.4/30.4	30.0
32.0	11.4	11.8	11.8	9.0	8.0	6.4	4.4	3.3	32.0
34.0	10.3	10.7	10.6	9.0	7.8	6.4	4.3	3.3	34.0
36.0	9.3	9.7	9.7	9.0	7.6	6.4	4.2	3.2	36.0
38.0	8.4	8.7	8.8	8.8	7.4	6.4	4.0	3.1	38.0
40.0	7.6	7.9	8.0	8.5	7.3	6.4	3.9	3.1	40.0
42.0	6.9	7.2	7.3	7.8	7.1	6.2	3.8	3.0	42.0
44.0	6.3	6.6	6.7	7.1	6.9	6.0	3.7	2.9	44.0
46.0	5.8	6.0	6.1	6.5	6.4	5.9	3.6	2.9	46.0
48.0	5.2	5.4	5.6	5.9	5.8	5.7	3.5	2.8	48.0
50.0	4.8	4.9	5.1	5.4	5.4	5.6	3.4	2.8	50.0
52.0	4.3	4.5	4.6	4.9	4.9	5.4	3.3	2.7	52.0
54.0	3.9	4.1	4.2	4.5	4.5	4.9	3.3	2.7	54.0
56.0	3.6	3.7	3.9	4.1	4.1	4.5	3.2	2.7	56.0
58.0	3.2	3.3	3.5	3.7	3.8	4.1	3.1	2.6	58.0
60.0	2.9	3.0	3.2	3.4	3.4	3.8	3.0	2.6	60.0
62.0	2.8/60.8	2.8/61.4	2.9	3.1	3.1	3.4	3.0	2.6	62.0
64.0			2.6	2.8	2.9	3.1	2.9	2.6	64.0
66.0			2.4	2.5	2.6	2.8	2.8	2.6	66.0
68.0			2.3/66.5	2.3/67.4	2.4	2.5	2.5	2.6	68.0
70.0					2.1	2.3	2.3	2.6	70.0
72.0					1.9	2.0	2.1	2.3	72.0
74.0					1.9/72.1	1.9/72.7	1.9	2.1	74.0
76.0								1.9/75.3	76.0

■ Crane Jib



Unit: ton

Boom length (m)		60								Boom length (m)	
Jib length (m)		10		16		22		28		Jib length (m)	
Offset angle (deg)	Radius (m)	10	30	10	30	10	30	10	30	Offset angle (deg)	Radius (m)
16.2	12.0									16.2	
18.0	12.0		12.0/19.2	12.0/18.3						18.0	
20.0	12.0	12.0	12.0	12.0		8.8/20.4				20.0	
22.0	12.0	12.0	12.0	12.0	9.0/23.1	8.8		5.3/22.5		22.0	
24.0	12.0	12.0	12.0	12.0	9.0	8.8		5.1		24.0	
26.0	12.0	12.0	12.0	12.0	9.0	8.8	6.4/27.0	5.0		26.0	
28.0	12.0	12.0	12.0	12.0	9.0	8.5	6.4	4.8		28.0	
30.0	12.0	12.0	12.0	12.0	9.0	8.3	6.4	4.6	3.4/30.9	30.0	
32.0	11.3	11.8	11.8	11.7	9.0	8.1	6.4	4.5	3.3	32.0	
34.0	10.2	10.6	10.6	10.6	9.0	7.9	6.4	4.4	3.3	34.0	
36.0	9.2	9.6	9.6	9.6	9.0	7.7	6.4	4.2	3.2	36.0	
38.0	8.3	8.7	8.7	8.7	8.9	7.5	6.4	4.1	3.1	38.0	
40.0	7.5	7.9	7.9	7.9	8.5	7.4	6.4	4.0	3.1	40.0	
42.0	6.9	7.1	7.2	7.2	7.7	7.2	6.3	3.9	3.0	42.0	
44.0	6.2	6.5	6.6	6.6	7.0	6.8	6.1	3.8	3.0	44.0	
46.0	5.7	5.9	6.0	6.0	6.4	6.3	6.0	3.7	2.9	46.0	
48.0	5.1	5.3	5.5	5.8	5.7	5.8	5.8	3.6	2.9	48.0	
50.0	4.7	4.9	5.0	5.3	5.2	5.2	5.7	3.5	2.8	50.0	
52.0	4.2	4.4	4.5	4.9	4.9	4.8	5.3	3.4	2.8	52.0	
54.0	3.8	4.0	4.1	4.4	4.4	4.4	4.8	3.3	2.7	54.0	
56.0	3.5	3.6	3.8	4.0	4.0	4.0	4.4	3.2	2.7	56.0	
58.0	3.1	3.2	3.4	3.6	3.6	3.7	4.0	3.2	2.7	58.0	
60.0	2.8	2.9	3.1	3.3	3.3	3.3	3.7	3.1	2.6	60.0	
62.0	2.5	2.6	2.8	3.0	3.0	3.0	3.3	3.0	2.6	62.0	
64.0	2.3/63.4	2.3	2.5	2.7	2.7	2.7	3.0	2.9	2.6	64.0	
66.0			2.2	2.4	2.5	2.7	2.7	2.7	2.6	66.0	
68.0			2.0	2.1	2.2	2.4	2.4	2.4	2.6	68.0	
70.0			1.9/69.1	1.9/69.3	2.0	2.2	2.2	2.2	2.5	70.0	
72.0					1.9/71.0	1.9	1.9	1.9	2.2	72.0	
74.0									2.0	74.0	
76.0									1.9/75.0	76.0	

Unit: ton

Boom length (m)		63								Boom length (m)	
Jib length (m)		10		16		22		28		Jib length (m)	
Offset angle (deg)	Radius (m)	10	30	10	30	10	30	10	30	Offset angle (deg)	Radius (m)
16.2	12.0/16.8									16.2	
18.0	12.0		12.0/19.8	12.0/18.9						18.0	
20.0	12.0	12.0	12.0	12.0		8.8/21.0				20.0	
22.0	12.0	12.0	12.0	12.0	9.0/23.7	8.8		5.3/23.1		22.0	
24.0	12.0	12.0	12.0	12.0	9.0	8.8		5.2		24.0	
26.0	12.0	12.0	12.0	12.0	9.0	8.8	6.4/27.5	5.0		26.0	
28.0	12.0	12.0	12.0	12.0	9.0	8.6	6.4	4.9		28.0	
30.0	12.0	12.0	12.0	12.0	9.0	8.4	6.4	4.7	3.4/31.4	30.0	
32.0	11.1	11.6	11.5	11.5	9.0	8.2	6.4	4.6	3.4	32.0	
34.0	10.0	10.4	10.3	10.3	9.0	8.0	6.4	4.4	3.3	34.0	
36.0	9.0	9.4	9.4	9.4	9.0	7.8	6.4	4.3	3.2	36.0	
38.0	8.1	8.5	8.5	8.5	9.0	7.6	6.4	4.2	3.2	38.0	
40.0	7.3	7.7	7.7	7.7	8.3	7.5	6.4	4.0	3.1	40.0	
42.0	6.6	6.9	7.0	7.0	7.5	7.3	6.4	3.9	3.0	42.0	
44.0	6.0	6.3	6.3	6.3	6.8	6.6	6.2	3.8	3.0	44.0	
46.0	5.4	5.7	5.8	5.8	6.2	6.1	6.1	3.7	2.9	46.0	
48.0	4.9	5.1	5.2	5.2	5.7	5.5	5.9	3.6	2.9	48.0	
50.0	4.4	4.6	4.8	4.8	5.1	5.0	5.6	3.5	2.8	50.0	
52.0	4.0	4.2	4.3	4.3	4.7	4.6	5.1	3.5	2.8	52.0	
54.0	3.6	3.8	3.9	3.9	4.2	4.2	4.7	3.4	2.7	54.0	
56.0	3.2	3.4	3.5	3.5	3.8	3.8	4.2	3.3	2.7	56.0	
58.0	2.9	3.0	3.2	3.2	3.4	3.4	3.8	3.2	2.7	58.0	
60.0	2.6	2.7	2.9	2.9	3.1	3.1	3.5	3.2	2.7	60.0	
62.0	2.3	2.4	2.6	2.6	2.8	2.8	3.1	3.0	2.6	62.0	
64.0	2.0	2.1	2.3	2.3	2.5	2.5	2.8	2.7	2.6	64.0	
66.0	1.9/64.6	1.9/65.3	2.0	2.0	2.2	2.2	2.5	2.4	2.6	66.0	
68.0			1.9/67.0	1.9	2.0	2.0	2.3	2.2	2.6	68.0	
70.0					1.9/69.0	2.0	2.0	2.0	2.3	70.0	
72.0						1.9/70.6	1.9/70.6	2.0	2.0	72.0	
74.0								1.9/73.0	2.0	74.0	

■ Main Boom with Crane Jib



Unit: ton

Boom length (m)	24								Boom length (m)
Jib length (m)	10		16		22		28		Jib length (m)
Offset angle (deg)	10	30	10	30	10	30	10	30	Offset angle (deg)
Radius (m)									Radius (m)
6.3	80.0	80.0	80.0	80.0	80.0	80.0	80.0	80.0	6.3
7.0	80.0	80.0	80.0	80.0	80.0	80.0	80.0	80.0	7.0
8.0	80.0	80.0	80.0	80.0	80.0	80.0	80.0	80.0	8.0
9.0	72.6	72.2	71.9	71.2	71.1	70.1	70.2	68.8	9.0
10.0	62.0	61.6	61.3	60.7	60.5	59.7	59.7	58.5	10.0
12.0	47.5	47.3	46.9	46.5	46.2	45.5	45.4	44.5	12.0
14.0	38.2	38.0	37.6	37.3	36.9	36.4	36.1	35.5	14.0
16.0	31.6	31.5	31.0	30.8	30.4	30.0	29.6	29.2	16.0
18.0	26.8	26.7	26.2	26.1	25.6	25.4	24.9	24.6	18.0
20.0	23.1	23.0	22.5	22.4	21.9	21.8	21.2	21.0	20.0
22.0	20.2	20.1	19.6	19.6	19.0	18.9	18.4	18.3	22.0
24.0	19.8 /22.3	19.7 /22.3	19.2 /22.3	19.2 /22.3	18.6 /22.3	18.6 /22.3	18.0 /22.3	17.9 /22.3	24.0

Unit: ton

Boom length (m)	27								Boom length (m)
Jib length (m)	10		16		22		28		Jib length (m)
Offset angle (deg)	10	30	10	30	10	30	10	30	Offset angle (deg)
Radius (m)									Radius (m)
6.3	80.0 /6.8	80.0 /6.8	80.0 /6.8	80.0 /6.8	80.0 /6.8	80.0 /6.8	80.0 /6.8	80.0 /6.8	6.3
7.0	80.0	80.0	80.0	80.0	80.0	80.0	80.0	80.0	7.0
8.0	80.0	80.0	80.0	80.0	80.0	80.0	80.0	80.0	8.0
9.0	72.6	72.2	71.9	71.2	71.2	70.1	70.3	68.8	9.0
10.0	61.9	61.6	61.3	60.7	60.6	59.7	59.7	58.5	10.0
12.0	47.5	47.2	46.9	46.4	46.2	45.5	45.4	44.5	12.0
14.0	38.1	37.9	37.5	37.2	36.9	36.4	36.1	35.4	14.0
16.0	31.5	31.4	31.0	30.7	30.4	30.0	29.7	29.1	16.0
18.0	26.7	26.6	26.2	26.0	25.5	25.3	24.9	24.5	18.0
20.0	23.0	22.9	22.5	22.3	21.9	21.6	21.2	20.9	20.0
22.0	20.0	20.0	19.5	19.4	18.9	18.8	18.3	18.1	22.0
24.0	17.7	17.6	17.2	17.1	16.6	16.5	16.0	15.9	24.0
24.9	16.7 /24.9	16.7 /24.9	16.2 /24.9	16.2 /24.9	15.7 /24.9	15.6 /24.9	15.1 /24.9	15.0 /24.9	24.9

1. The rated loads determined according to EN13000 rating on the condition that the machine is stationed on firm, level ground.
2. The figures surrounded by bold lines are based on factors other than those which would cause a tipping condition.
3. To calculate the maximum load that can actually be lifted, deduct weight of all lifting accessories, such as boom hook and jib hook, from figures shown above.
4. Working radius is the horizontal distance from the slewing center to the center of gravity of a lifted load.
5. The offset angles shown are of jib boom offset angle against the main boom, under load.
6. The counterweight is 65.4 ton. (Superstructure 56.4ton + Undercarriage 9.0 ton)
7. Correlation between the number of reeved lines, maximum rated loads, hook weights are shown in the table below.

Hook Capacity (t)	Hook Weight (t)	Maximum rated loads (t)					
		6falls	5falls	4falls	3falls	2falls	1fall
150	2.35	81.0	67.5	54.0	40.5	27.0	
80	1.35	80.0	67.5	54.0	40.5	27.0	
35	0.90				35.0	27.0	
13.5	0.62						13.5

■ Main Boom with Crane Jib



Unit: ton

Boom length (m)	30								Boom length (m)
Jib length (m)	10		16		22		28		Jib length (m)
Offset angle (deg) Radius (m)	10	30	10	30	10	30	10	30	Offset angle (deg) Radius (m)
7.4	72.0	72.0	72.0	72.0	72.0	72.0	72.0	72.0	7.4
8.0	72.0	72.0	72.0	72.0	72.0	72.0	72.0	72.0	8.0
9.0	72.0	72.0	72.0	71.3	71.2	70.1	70.3	68.9	9.0
10.0	61.9	61.6	61.3	60.7	60.6	59.7	59.8	58.5	10.0
12.0	47.5	47.2	46.9	46.4	46.2	45.5	45.5	44.5	12.0
14.0	38.1	37.9	37.5	37.2	36.9	36.4	36.2	35.5	14.0
16.0	31.5	31.4	31.0	30.7	30.4	30.0	29.7	29.1	16.0
18.0	26.7	26.6	26.2	25.9	25.6	25.2	24.9	24.5	18.0
20.0	23.0	22.9	22.4	22.3	21.9	21.6	21.2	20.9	20.0
22.0	20.0	19.9	19.5	19.4	19.0	18.8	18.3	18.1	22.0
24.0	17.6	17.6	17.1	17.0	16.6	16.4	16.0	15.8	24.0
26.0	15.6	15.6	15.2	15.1	14.6	14.5	14.0	13.9	26.0
28.0	14.4 /27.5	14.3 /27.5	13.9 /27.5	13.9 /27.5	13.4 /27.5	13.3 /27.5	12.8 /27.5	12.7 /27.5	28.0

Unit: ton

Boom length (m)	33								Boom length (m)
Jib length (m)	10		16		22		28		Jib length (m)
Offset angle (deg) Radius (m)	10	30	10	30	10	30	10	30	Offset angle (deg) Radius (m)
7.4	72.0 /7.9	72.0 /7.9	72.0 /7.9	72.0 /7.9	72.0 /7.9	72.0 /7.9	72.0 /7.9	72.0 /7.9	7.4
8.0	72.0	72.0	72.0	72.0	72.0	72.0	72.0	72.0	8.0
9.0	71.5	71.1	70.7	70.1	69.9	68.9	68.9	67.6	9.0
10.0	61.9	61.5	61.3	60.6	60.6	59.6	59.8	58.5	10.0
12.0	47.4	47.1	46.8	46.3	46.2	45.5	45.5	44.5	12.0
14.0	38.0	37.8	37.4	37.1	36.8	36.3	36.2	35.4	14.0
16.0	31.4	31.2	30.9	30.6	30.3	29.9	29.7	29.1	16.0
18.0	26.6	26.4	26.1	25.8	25.5	25.1	24.9	24.4	18.0
20.0	22.8	22.7	22.4	22.2	21.8	21.5	21.2	20.8	20.0
22.0	19.9	19.8	19.4	19.3	18.9	18.6	18.3	18.0	22.0
24.0	17.5	17.4	17.0	16.9	16.5	16.3	15.9	15.7	24.0
26.0	15.5	15.5	15.1	15.0	14.5	14.4	14.0	13.8	26.0
28.0	13.9	13.8	13.4	13.3	12.9	12.8	12.3	12.2	28.0
30.0	12.5	12.4	12.0	12.0	11.5	11.5	11.0	10.9	30.0
30.1	12.4 /30.1	12.4 /30.1	12.0 /30.1	11.9 /30.1	11.5 /30.1	11.4 /30.1	10.9 /30.1	10.8 /30.1	30.1

■ Main Boom with Crane Jib



Unit: ton

Boom length (m)	36								Boom length (m)
Jib length (m)	10		16		22		28		Jib length (m)
Offset angle (deg) Radius (m)	10	30	10	30	10	30	10	30	Offset angle (deg) Radius (m)
8.5	60.0	60.0	60.0	60.0	60.0	60.0	60.0	60.0	8.5
9.0	60.0	60.0	60.0	60.0	60.0	60.0	60.0	60.0	9.0
10.0	60.0	60.0	60.0	60.0	60.0	60.0	59.2	59.2	10.0
12.0	47.3	47.0	46.7	46.3	46.1	45.4	45.4	44.4	12.0
14.0	37.9	37.7	37.4	37.0	36.8	36.2	36.1	35.3	14.0
16.0	31.3	31.1	30.8	30.5	30.2	29.8	29.6	29.0	16.0
18.0	26.5	26.3	26.0	25.7	25.4	25.0	24.8	24.3	18.0
20.0	22.7	22.6	22.2	22.0	21.7	21.4	21.1	20.7	20.0
22.0	19.8	19.7	19.3	19.1	18.8	18.5	18.2	17.9	22.0
24.0	17.4	17.3	16.9	16.8	16.4	16.2	15.8	15.5	24.0
26.0	15.4	15.3	14.9	14.8	14.4	14.3	13.9	13.7	26.0
28.0	13.7	13.7	13.3	13.2	12.8	12.6	12.2	12.1	28.0
30.0	12.3	12.2	11.9	11.8	11.4	11.3	10.8	10.7	30.0
32.0	11.1	11.0	10.6	10.6	10.2	10.1	9.6	9.6	32.0
34.0	10.7 /32.7	10.7 /32.7	10.3 /32.7	10.2 /32.7	9.8 /32.7	9.7 /32.7	9.3 /32.7	9.2 /32.7	34.0

Unit: ton

Boom length (m)	39								Boom length (m)
Jib length (m)	10		16		22		28		Jib length (m)
Offset angle (deg) Radius (m)	10	30	10	30	10	30	10	30	Offset angle (deg) Radius (m)
9.0	60.0	60.0	60.0	60.0	60.0	60.0	60.0	60.0	9.0
10.0	60.0	60.0	59.7	59.1	58.9	58.1	58.1	56.9	10.0
12.0	47.2	46.9	46.6	46.2	46.0	45.3	45.4	44.3	12.0
14.0	37.8	37.5	37.3	36.9	36.7	36.1	36.1	35.2	14.0
16.0	31.2	31.0	30.7	30.4	30.2	29.7	29.5	28.9	16.0
18.0	26.3	26.2	25.9	25.6	25.3	24.9	24.7	24.2	18.0
20.0	22.6	22.5	22.1	21.9	21.6	21.3	21.0	20.6	20.0
22.0	19.6	19.5	19.2	19.0	18.7	18.4	18.1	17.7	22.0
24.0	17.2	17.1	16.8	16.6	16.3	16.1	15.7	15.4	24.0
26.0	15.2	15.2	14.8	14.7	14.3	14.1	13.8	13.5	26.0
28.0	13.6	13.5	13.1	13.0	12.7	12.5	12.1	11.9	28.0
30.0	12.2	12.1	11.7	11.6	11.2	11.1	10.7	10.6	30.0
32.0	10.9	10.9	10.5	10.4	10.0	9.9	9.5	9.4	32.0
34.0	9.9	9.8	9.5	9.4	9.0	8.9	8.5	8.4	34.0
35.3	9.3 /35.3	9.2 /35.3	8.8 /35.3	8.8 /35.3	8.4 /35.3	8.3 /35.3	7.9 /35.3	7.8 /35.3	35.3

■ Main Boom with Crane Jib



Unit: ton

Boom length (m)	42								Boom length (m)
Jib length (m)	10		16		22		28		Jib length (m)
Offset angle (deg) Radius (m)	10	30	10	30	10	30	10	30	Offset angle (deg) Radius (m)
9.6	48.0	48.0	48.0	48.0	48.0	48.0	48.0	48.0	9.6
10.0	48.0	48.0	48.0	48.0	48.0	48.0	48.0	48.0	10.0
12.0	47.1	46.9	46.6	46.1	46.0	45.3	45.4	44.3	12.0
14.0	37.7	37.5	37.2	36.8	36.7	36.1	36.1	35.2	14.0
16.0	31.1	31.0	30.7	30.3	30.1	29.6	29.5	28.9	16.0
18.0	26.3	26.1	25.8	25.5	25.3	24.9	24.7	24.1	18.0
20.0	22.5	22.4	22.1	21.8	21.6	21.2	21.0	20.5	20.0
22.0	19.6	19.4	19.1	18.9	18.6	18.3	18.1	17.7	22.0
24.0	17.2	17.1	16.7	16.5	16.2	16.0	15.7	15.4	24.0
26.0	15.2	15.1	14.7	14.6	14.3	14.0	13.7	13.4	26.0
28.0	13.5	13.4	13.1	12.9	12.6	12.4	12.1	11.8	28.0
30.0	12.1	12.0	11.6	11.5	11.2	11.0	10.7	10.5	30.0
32.0	10.8	10.8	10.4	10.3	10.0	9.8	9.5	9.3	32.0
34.0	9.8	9.7	9.4	9.3	8.9	8.8	8.4	8.3	34.0
36.0	8.8	8.8	8.4	8.4	8.0	7.9	7.5	7.4	36.0
38.0	8.0 /37.9	8.0 /37.9	7.6 /37.9	7.6 /37.9	7.2 /37.9	7.2 /37.9	6.7 /37.9	6.7 /37.9	38.0

Unit: ton

Boom length (m)	45								Boom length (m)
Jib length (m)	10		16		22		28		Jib length (m)
Offset angle (deg) Radius (m)	10	30	10	30	10	30	10	30	Offset angle (deg) Radius (m)
10.0	48.0 /10.1	48.0 /10.1	48.0 /10.1	48.0 /10.1	48.0 /10.1	48.0 /10.1	48.0 /10.1	48.0 /10.1	10.0
12.0	46.7	46.4	46.1	45.6	45.4	44.7	44.6	43.7	12.0
14.0	37.6	37.3	37.1	36.7	36.5	35.9	35.9	35.1	14.0
16.0	31.0	30.8	30.5	30.1	30.0	29.5	29.4	28.7	16.0
18.0	26.1	25.9	25.6	25.3	25.1	24.7	24.6	24.0	18.0
20.0	22.3	22.2	21.9	21.6	21.4	21.0	20.8	20.4	20.0
22.0	19.4	19.2	18.9	18.7	18.4	18.1	17.9	17.5	22.0
24.0	17.0	16.8	16.5	16.3	16.0	15.8	15.5	15.2	24.0
26.0	15.0	14.9	14.5	14.4	14.1	13.8	13.5	13.2	26.0
28.0	13.3	13.2	12.9	12.7	12.4	12.2	11.9	11.6	28.0
30.0	11.8	11.8	11.4	11.3	11.0	10.8	10.5	10.3	30.0
32.0	10.6	10.6	10.2	10.1	9.8	9.6	9.3	9.1	32.0
34.0	9.5	9.5	9.1	9.1	8.7	8.6	8.2	8.1	34.0
36.0	8.6	8.6	8.2	8.1	7.8	7.7	7.3	7.2	36.0
38.0	7.8	7.7	7.4	7.3	7.0	6.9	6.5	6.4	38.0
40.0	7.0	7.0	6.7	6.6	6.2	6.2	5.8	5.7	40.0
40.5	6.9 /40.5	6.8 /40.5	6.5 /40.5	6.5 /40.5	6.1 /40.5	6.0 /40.5	5.6 /40.5	5.6 /40.5	40.5

■ Main Boom with Crane Jib



Unit: ton

Boom length (m)	48								Boom length (m)
Jib length (m)	10		16		22		28		Jib length (m)
Offset angle (deg) Radius (m)	10	30	10	30	10	30	10	30	Offset angle (deg) Radius (m)
10.6	36.0	36.0	36.0	36.0	36.0	36.0	36.0	36.0	10.6
12.0	36.0	36.0	36.0	36.0	36.0	36.0	36.0	36.0	12.0
14.0	36.0	36.0	36.0	36.0	36.0	36.0	35.9	35.9	14.0
16.0	30.9	30.7	30.5	30.1	29.9	29.4	29.4	28.7	16.0
18.0	26.0	25.9	25.6	25.3	25.1	24.7	24.5	23.9	18.0
20.0	22.3	22.1	21.8	21.6	21.4	21.0	20.8	20.3	20.0
22.0	19.3	19.2	18.9	18.7	18.4	18.1	17.9	17.4	22.0
24.0	16.9	16.8	16.5	16.3	16.0	15.7	15.5	15.1	24.0
26.0	14.9	14.8	14.5	14.3	14.0	13.8	13.5	13.2	26.0
28.0	13.2	13.1	12.8	12.7	12.3	12.1	11.9	11.6	28.0
30.0	11.8	11.7	11.4	11.2	10.9	10.7	10.4	10.2	30.0
32.0	10.5	10.5	10.1	10.0	9.7	9.5	9.2	9.0	32.0
34.0	9.5	9.4	9.1	9.0	8.6	8.5	8.2	8.0	34.0
36.0	8.5	8.5	8.1	8.0	7.7	7.6	7.2	7.1	36.0
38.0	7.7	7.6	7.3	7.2	6.9	6.8	6.4	6.3	38.0
40.0	6.9	6.9	6.6	6.5	6.1	6.1	5.7	5.6	40.0
42.0	6.3	6.2	5.9	5.9	5.5	5.4	5.0	5.0	42.0
44.0	5.9 /43.1	5.9 /43.1	5.6 /43.1	5.5 /43.1	5.1 /43.1	5.1 /43.1	4.7 /43.1	4.7 /43.1	44.0

Unit: ton

Boom length (m)	51								Boom length (m)
Jib length (m)	10		16		22		28		Jib length (m)
Offset angle (deg) Radius (m)	10	30	10	30	10	30	10	30	Offset angle (deg) Radius (m)
10.6	36.0 /11.2	36.0 /11.2	36.0 /11.2	36.0 /11.2	36.0 /11.2	36.0 /11.2	36.0 /11.2	36.0 /11.2	10.6
12.0	36.0	36.0	36.0	36.0	36.0	36.0	36.0	36.0	12.0
14.0	36.0	36.0	36.0	36.0	36.0	35.6	35.5	34.7	14.0
16.0	30.8	30.6	30.3	30.0	29.8	29.3	29.3	28.5	16.0
18.0	25.9	25.7	25.4	25.1	25.0	24.5	24.4	23.8	18.0
20.0	22.1	22.0	21.7	21.4	21.2	20.8	20.7	20.2	20.0
22.0	19.2	19.0	18.7	18.5	18.3	17.9	17.8	17.3	22.0
24.0	16.7	16.6	16.3	16.1	15.9	15.6	15.4	15.0	24.0
26.0	14.7	14.6	14.3	14.1	13.9	13.6	13.4	13.0	26.0
28.0	13.0	13.0	12.6	12.5	12.2	12.0	11.7	11.4	28.0
30.0	11.6	11.5	11.2	11.1	10.8	10.6	10.3	10.0	30.0
32.0	10.4	10.3	10.0	9.9	9.5	9.4	9.1	8.9	32.0
34.0	9.3	9.2	8.9	8.8	8.5	8.3	8.0	7.8	34.0
36.0	8.3	8.3	8.0	7.9	7.5	7.4	7.1	6.9	36.0
38.0	7.5	7.5	7.1	7.1	6.7	6.6	6.3	6.1	38.0
40.0	6.8	6.7	6.4	6.3	6.0	5.9	5.5	5.4	40.0
42.0	6.1	6.1	5.7	5.7	5.3	5.2	4.9	4.8	42.0
44.0	5.5	5.5	5.1	5.1	4.7	4.7	4.3	4.2	44.0
45.7	5.0 /45.7	5.0 /45.7	4.7 /45.7	4.6 /45.7	4.3 /45.7	4.2 /45.7	3.8 /45.7	3.8 /45.7	45.7

■ Main Boom with Crane Jib



Unit: ton

Boom length (m)	54								Boom length (m)
Jib length (m)	10		16		22		28		Jib length (m)
Offset angle (deg) Radius (m)	10	30	10	30	10	30	10	30	Offset angle (deg) Radius (m)
11.7	36.0	36.0	36.0	36.0	36.0	36.0	35.9	35.6	11.7
12.0	36.0	36.0	36.0	36.0	36.0	36.0	35.5	35.3	12.0
14.0	36.0	36.0	35.2	35.2	34.1	34.1	32.9	32.9	14.0
16.0	30.6	30.4	30.1	29.8	29.6	29.1	29.1	28.3	16.0
18.0	25.7	25.5	25.3	24.9	24.8	24.3	24.2	23.6	18.0
20.0	21.9	21.8	21.5	21.2	21.0	20.6	20.5	20.0	20.0
22.0	18.9	18.8	18.5	18.3	18.1	17.7	17.6	17.1	22.0
24.0	16.5	16.4	16.1	15.9	15.7	15.4	15.2	14.8	24.0
26.0	14.5	14.4	14.1	13.9	13.7	13.4	13.2	12.8	26.0
28.0	12.8	12.7	12.4	12.3	12.0	11.8	11.5	11.2	28.0
30.0	11.4	11.3	11.0	10.9	10.6	10.4	10.1	9.8	30.0
32.0	10.2	10.1	9.8	9.6	9.3	9.2	8.9	8.6	32.0
34.0	9.1	9.0	8.7	8.6	8.3	8.1	7.8	7.6	34.0
36.0	8.1	8.1	7.7	7.6	7.3	7.2	6.9	6.7	36.0
38.0	7.3	7.2	6.9	6.8	6.5	6.4	6.0	5.9	38.0
40.0	6.5	6.5	6.2	6.1	5.8	5.7	5.3	5.2	40.0
42.0	5.9	5.8	5.5	5.4	5.1	5.0	4.7	4.6	42.0
44.0	5.3	5.2	4.9	4.8	4.5	4.4	4.1	4.0	44.0
46.0	4.7	4.7	4.4	4.3	4.0	3.9	3.5	3.5	46.0
48.0	4.2	4.2	3.9	3.8	3.5	3.4	3.1	3.0	48.0
50.0	4.2 / 48.3	4.1 / 48.3	3.8 / 48.3	3.8 / 48.3	3.4 / 48.3	3.4 / 48.3	3.0 / 48.3	3.0 / 48.3	50.0

Unit: ton

Boom length (m)	57								Boom length (m)
Jib length (m)	10		16		22		28		Jib length (m)
Offset angle (deg) Radius (m)	10	30	10	30	10	30	10	30	Offset angle (deg) Radius (m)
12.0	35.2 / 12.3	35.1 / 12.3	34.1 / 12.3	34.1 / 12.3	33.0 / 12.3	32.8 / 12.3	31.7 / 12.3	31.4 / 12.3	12.0
14.0	33.0	32.9	32.0	32.0	30.9	30.9	29.7	29.6	14.0
16.0	30.4	30.2	29.6	29.6	28.6	28.6	27.5	27.5	16.0
18.0	25.5	25.4	25.1	24.8	24.6	24.2	24.1	23.5	18.0
20.0	21.8	21.6	21.3	21.1	20.9	20.5	20.4	19.8	20.0
22.0	18.8	18.6	18.4	18.1	17.9	17.6	17.4	16.9	22.0
24.0	16.4	16.2	16.0	15.7	15.5	15.2	15.0	14.6	24.0
26.0	14.4	14.2	14.0	13.8	13.5	13.2	13.0	12.7	26.0
28.0	12.7	12.6	12.3	12.1	11.8	11.6	11.4	11.0	28.0
30.0	11.2	11.1	10.8	10.7	10.4	10.2	9.9	9.7	30.0
32.0	10.0	9.9	9.6	9.5	9.2	9.0	8.7	8.5	32.0
34.0	8.9	8.8	8.5	8.4	8.1	7.9	7.7	7.4	34.0
36.0	8.0	7.9	7.6	7.5	7.2	7.0	6.7	6.5	36.0
38.0	7.1	7.1	6.7	6.6	6.3	6.2	5.9	5.7	38.0
40.0	6.4	6.3	6.0	5.9	5.6	5.5	5.1	5.0	40.0
42.0	5.7	5.6	5.3	5.3	4.9	4.8	4.5	4.4	42.0
44.0	5.1	5.0	4.7	4.7	4.3	4.2	3.9	3.8	44.0
46.0	4.5	4.5	4.2	4.1	3.8	3.7	3.4	3.3	46.0
48.0	4.1	4.0	3.7	3.7	3.3	3.3	2.9	2.8	48.0
50.0	3.6	3.6	3.3	3.2	2.9	2.8	2.5	2.4	50.0
50.9	3.4 / 50.9	3.4 / 50.9	3.1 / 50.9	3.0 / 50.9	2.7 / 50.9	2.7 / 50.9	2.3 / 50.9	2.2 / 50.9	50.9

■ Main Boom with Crane Jib



Unit: ton

Boom length (m)	60								Boom length (m)
Jib length (m)	10		16		22		28		Jib length (m)
Offset angle (deg) Radius (m)	10	30	10	30	10	30	10	30	Offset angle (deg) Radius (m)
12.9	24.0	24.0	24.0	24.0	24.0	24.0	24.0	24.0	12.9
14.0	24.0	24.0	24.0	24.0	24.0	24.0	24.0	24.0	14.0
16.0	24.0	24.0	24.0	24.0	24.0	24.0	24.0	24.0	16.0
18.0	24.0	24.0	24.0	24.0	23.3	23.3	22.3	22.4	18.0
20.0	21.7	21.6	21.3	21.1	20.9	20.5	20.4	19.8	20.0
22.0	18.7	18.6	18.3	18.1	17.9	17.5	17.4	16.9	22.0
24.0	16.3	16.2	15.9	15.7	15.5	15.2	15.0	14.6	24.0
26.0	14.3	14.2	13.9	13.7	13.5	13.2	13.0	12.6	26.0
28.0	12.6	12.5	12.2	12.0	11.8	11.5	11.3	11.0	28.0
30.0	11.2	11.1	10.8	10.6	10.3	10.1	9.9	9.6	30.0
32.0	9.9	9.8	9.5	9.4	9.1	8.9	8.7	8.4	32.0
34.0	8.8	8.7	8.4	8.3	8.0	7.8	7.6	7.3	34.0
36.0	7.9	7.8	7.5	7.4	7.1	6.9	6.6	6.4	36.0
38.0	7.0	7.0	6.6	6.5	6.2	6.1	5.8	5.6	38.0
40.0	6.3	6.2	5.9	5.8	5.5	5.4	5.1	4.9	40.0
42.0	5.6	5.5	5.2	5.1	4.8	4.7	4.4	4.3	42.0
44.0	5.0	4.9	4.6	4.5	4.2	4.1	3.8	3.7	44.0
46.0	4.4	4.4	4.1	4.0	3.7	3.6	3.3	3.2	46.0
48.0	3.9	3.9	3.6	3.5	3.2	3.1	2.8	2.7	48.0
50.0	3.5	3.4	3.1	3.1	2.7	2.7	2.3	2.3	50.0
52.0	3.0	3.0	2.7	2.7	2.3	2.3	1.9	1.9	52.0
54.0	2.8 /53.2	2.8 /53.2	2.5 /53.2	2.4 /53.2	2.1 /53.2	2.1 /53.2			54.0

Unit: ton

Boom length (m)	63								Boom length (m)
Jib length (m)	10		16		22		28		Jib length (m)
Offset angle (deg) Radius (m)	10	30	10	30	10	30	10	30	Offset angle (deg) Radius (m)
12.9	24.0 /13.5	24.0 /13.5	24.0 /13.5	24.0 /13.5	24.0 /13.5	24.0 /13.5	23.8 /13.5	23.6 /13.5	12.9
14.0	24.0	24.0	24.0	24.0	24.0	24.0	23.3	23.2	14.0
16.0	24.0	24.0	23.5	23.5	22.6	22.6	21.6	21.5	16.0
18.0	22.5	22.5	21.7	21.7	20.9	20.9	19.9	19.9	18.0
20.0	20.7	20.8	20.0	20.1	19.3	19.3	18.3	18.4	20.0
22.0	18.5	18.4	18.1	17.9	17.7	17.3	16.9	16.7	22.0
24.0	16.1	16.0	15.7	15.5	15.3	15.0	14.8	14.4	24.0
26.0	14.1	14.0	13.7	13.5	13.3	13.0	12.8	12.4	26.0
28.0	12.4	12.3	12.0	11.8	11.6	11.3	11.1	10.8	28.0
30.0	10.9	10.8	10.6	10.4	10.1	9.9	9.7	9.4	30.0
32.0	9.7	9.6	9.3	9.2	8.9	8.7	8.5	8.2	32.0
34.0	8.6	8.5	8.2	8.1	7.8	7.6	7.4	7.1	34.0
36.0	7.6	7.6	7.3	7.2	6.9	6.7	6.4	6.2	36.0
38.0	6.8	6.7	6.4	6.3	6.0	5.9	5.6	5.4	38.0
40.0	6.0	6.0	5.7	5.6	5.3	5.1	4.8	4.7	40.0
42.0	5.4	5.3	5.0	4.9	4.6	4.5	4.2	4.0	42.0
44.0	4.8	4.7	4.4	4.3	4.0	3.9	3.6	3.4	44.0
46.0	4.2	4.2	3.8	3.8	3.4	3.4	3.0	2.9	46.0
48.0	3.7	3.7	3.3	3.3	3.0	2.9	2.5	2.4	48.0
50.0	3.2	3.2	2.9	2.8	2.5	2.4	2.1	2.0	50.0
52.0	2.8	2.8	2.5	2.4	2.1	2.0	1.9 /51.0	1.9 /50.5	52.0
54.0	2.4	2.4	2.1	2.1	1.9 /53.0	1.9 /52.6			54.0
55.8	2.1 /55.8	2.1 /55.8	1.9 /55.2	1.9 /54.9					55.8



■ Main Boom (Using Third Winch)

Unit: ton

Working Radius(m)	Boom length (m)											Working Radius(m)
	15	18	21	24	27	30	33	36	39	42	45	
4.5	132.0											4.5
5.0	132.0	108.0 /5.2										5.0
5.5	123.5	108.0	84.0 /5.7									5.5
6.0	113.6	108.0	84.0	72.0 /6.3	72.0 /6.8							6.0
7.0	97.7	97.6	84.0	72.0	72.0	60.0 /7.4	48.0 /7.9					7.0
8.0	85.6	85.5	84.0	72.0	72.0	60.0	48.0	48.0 /8.5				8.0
9.0	73.4	73.5	74.0	72.0	72.0	60.0	48.0	48.0	48.0	36.0 /9.6		9.0
10.0	62.8	62.9	63.4	63.4	63.3	60.0	48.0	48.0	48.0	36.0	36.0 /10.1	10.0
12.0	48.5	48.5	48.9	48.9	48.8	48.8	48.0	48.0	48.0	36.0	36.0	12.0
14.0	39.1	39.2	39.6	39.6	39.4	39.4	39.4	39.2	39.1	36.0	36.0	14.0
16.0	37.3 /14.5	32.7	33.0	33.0	32.9	32.9	32.8	32.6	32.5	32.5	32.3	16.0
18.0		29.8 /17.1	28.2	28.2	28.1	28.0	28.0	27.8	27.7	27.6	27.4	18.0
20.0			25.0 /19.7	24.5	24.3	24.3	24.2	24.1	23.9	23.9	23.7	20.0
22.0				21.5	21.4	21.3	21.3	21.1	21.0	20.9	20.7	22.0
24.0				21.1 /22.3	19.0	18.9	18.9	18.7	18.5	18.5	18.3	24.0
26.0					18.0 /24.9	16.9	16.9	16.7	16.6	16.5	16.3	26.0
28.0						15.7 /27.5	15.2	15.0	14.9	14.8	14.6	28.0
30.0							13.8	13.6	13.4	13.4	13.2	30.0
32.0							13.7 /30.1	12.3	12.2	12.1	11.9	32.0
34.0								12.0 /32.7	11.1	11.0	10.8	34.0
36.0									10.5 /35.3	10.1	9.9	36.0
38.0										9.3 /37.9	9.0	38.0
40.0											8.3	40.0
42.0											8.1 /40.5	42.0

Unit: ton

Working Radius(m)	Boom length (m)						Working Radius(m)
	48	51	54	57	60	63	
10.0	36.0 /10.6	24.0 /11.3	24.0 /11.8				10.0
12.0	36.0	24.0	24.0	24.0 /12.4	24.0 /12.9	24.0 /13.5	12.0
14.0	36.0	24.0	24.0	24.0	24.0	24.0	14.0
16.0	32.2	24.0	24.0	24.0	24.0	24.0	16.0
18.0	27.3	24.0	24.0	24.0	24.0	24.0	18.0
20.0	23.5	23.5	23.3	23.1	23.0	22.8	20.0
22.0	20.5	20.5	20.3	20.2	20.0	19.8	22.0
24.0	18.1	18.1	17.9	17.7	17.6	17.4	24.0
26.0	16.1	16.1	15.9	15.7	15.5	15.3	26.0
28.0	14.4	14.4	14.2	14.0	13.9	13.6	28.0
30.0	13.0	12.9	12.7	12.6	12.4	12.2	30.0
32.0	11.8	11.7	11.5	11.3	11.2	10.9	32.0
34.0	10.7	10.6	10.4	10.2	10.1	9.9	34.0
36.0	9.7	9.6	9.4	9.3	9.1	8.9	36.0
38.0	8.9	8.8	8.6	8.4	8.3	8.0	38.0
40.0	8.1	8.0	7.8	7.7	7.5	7.3	40.0
42.0	7.5	7.3	7.1	7.0	6.8	6.6	42.0
44.0	7.1 /43.1	6.7	6.5	6.4	6.2	6.0	44.0
46.0		6.3 /45.5	6.0	5.8	5.6	5.4	46.0
48.0			5.5	5.3	5.1	4.9	48.0
50.0			5.4 /48.1	4.8	4.7	4.5	50.0
52.0				4.7 /50.6	4.2	4.0	52.0
54.0					4.0 /53.2	3.6	54.0
56.0						3.3 /55.8	56.0

- The rated loads are determined according to EN13000 rating on the condition that the machine is stationed on firm, level ground.
- The figures surrounded by bold lines are based on factors other than those which would cause a tipping condition.
- Be sure to attach the hanger sheaves block to the top boom when boom length is 15m.
- Be sure to remove the hanger sheaves block from the top boom when boom length is 18m or more.
- To calculate the maximum load that can actually be lifted, deduct weight of all lifting accessories, such as boom hook and jib hook, from figures shown above.
- Working radius is the horizontal distance from the slewing center to the center of gravity of a lifted load.
- The counterweight is 65.4ton. (Superstructure 56.4ton + Undercarriage 9.0 ton)
- Correlation between the number of reeved lines, maximum rated loads, hook weights are shown in the table below.

Hook Capacity (t)	Hook Weight (t)	Maximum rated loads (t)									
		11falls	10falls	9falls	8falls	7falls	6falls	5falls	4falls	3falls	2falls
150	2.35	132.0	120.0	108.0	96.0	84.0	72.0	60.0	48.0	36.0	24.0
80	1.35					80.0	72.0	60.0	48.0	36.0	24.0
35	0.90									35.0	24.0

■ Main Boom with Aux. Sheave (Using Third Winch)



Radius (m)	Boom length (m)											Radius (m)
	15	18	21	24	27	30	33	36	39	42	45	
4.5	132.0											4.5
5.0	132.0	108.0/5.2										5.0
5.5	122.6	108.0	84.0/5.7									5.5
6.0	112.7	108.0	84.0	72.0/6.3	72.0/6.8							6.0
7.0	96.9	96.8	84.0	72.0	72.0	60.0/7.4	48.0/7.9					7.0
8.0	84.8	84.7	84.0	72.0	72.0	60.0	48.0	48.0/8.5				8.0
9.0	73.0	73.1	73.6	72.0	72.0	60.0	48.0	48.0	48.0	36.0/9.6		9.0
10.0	62.4	62.5	62.9	63.0	62.8	60.0	48.0	48.0	48.0	36.0	36.0/10.1	10.0
12.0	48.1	48.1	48.5	48.5	48.4	48.4	48.0	48.0	48.0	36.0	36.0	12.0
14.0	38.8	38.8	39.2	39.2	39.1	39.0	39.0	38.8	38.7	36.0	36.0	14.0
16.0	37.0/14.5	32.3	32.7	32.7	32.5	32.5	32.4	32.2	32.1	32.0	31.9	16.0
18.0		29.5/17.1	27.9	27.9	27.7	27.6	27.6	27.4	27.2	27.2	27.0	18.0
20.0			24.6/19.7	24.1	24.0	23.9	23.9	23.7	23.5	23.4	23.2	20.0
22.0				21.2	21.0	21.0	20.9	20.7	20.6	20.5	20.3	22.0
24.0				20.8/22.3	18.6	18.6	18.5	18.3	18.2	18.1	17.9	24.0
26.0					17.7/24.9	16.6	16.5	16.3	16.2	16.1	15.9	26.0
28.0						15.3/27.5	14.9	14.6	14.5	14.4	14.2	28.0
30.0							13.4	13.2	13.1	13.0	12.8	30.0
32.0							13.4/30.1	12.0	11.8	11.7	11.5	32.0
34.0								11.6/32.7	10.8	10.7	10.4	34.0
36.0									10.2/35.3	9.7	9.5	36.0
38.0										8.9/37.9	8.7	38.0
40.0											7.9	40.0
42.0											7.8/40.5	42.0

Radius (m)	Boom length (m)						Radius (m)
	48	51	54	57	60	63	
10.0	36.0/10.6	24.0/11.3	24.0/11.8				10.0
12.0	36.0	24.0	24.0	24.0/12.4	24.0/12.9	24.0/13.5	12.0
14.0	36.0	24.0	24.0	24.0	24.0	24.0	14.0
16.0	31.7	24.0	24.0	24.0	24.0	24.0	16.0
18.0	26.8	24.0	24.0	24.0	24.0	24.0	18.0
20.0	23.1	23.0	22.8	22.7	22.5	22.2	20.0
22.0	20.1	20.0	19.8	19.7	19.5	19.3	22.0
24.0	17.7	17.6	17.4	17.3	17.1	16.9	24.0
26.0	15.7	15.6	15.4	15.2	15.1	14.9	26.0
28.0	14.0	13.9	13.7	13.6	13.4	13.2	28.0
30.0	12.6	12.5	12.3	12.1	11.9	11.7	30.0
32.0	11.4	11.3	11.0	10.9	10.7	10.5	32.0
34.0	10.3	10.2	10.0	9.8	9.6	9.4	34.0
36.0	9.3	9.2	9.0	8.8	8.7	8.4	36.0
38.0	8.5	8.4	8.2	8.0	7.8	7.6	38.0
40.0	7.8	7.6	7.4	7.2	7.1	6.8	40.0
42.0	7.1	7.0	6.7	6.6	6.4	6.2	42.0
44.0	6.8/43.1	6.3	6.1	5.9	5.8	5.5	44.0
46.0		5.9/45.5	5.6	5.4	5.2	5.0	46.0
48.0			5.1	4.9	4.7	4.5	48.0
50.0			5.0/48.1	4.4	4.3	4.0	50.0
52.0				4.3/50.6	3.8	3.6	52.0
54.0					3.6/53.2	3.2	54.0
56.0						2.9/55.8	56.0

- The rated loads are determined according to EN13000 rating on the condition that the machine is stationed on firm, level ground.
- The figures surrounded by bold lines are based on factors other than those which would cause a tipping condition.
- Be sure to attach the hanger sheaves block to the top boom when boom length is 15m.
- Be sure to remove the hanger sheaves block from the top boom when boom length is 18m or more.
- To calculate the maximum load that can actually be lifted, deduct weight of all lifting accessories, such as boom hook and jib hook, from figures shown above.
- Working radius is the horizontal distance from the slewing center to the center of gravity of a lifted load.
- The counterweight is 65.4ton. (Superstructure 56.4ton + Undercarriage 9.0 ton)
- Correlation between the number of reeved lines, maximum rated loads, hook weights are shown in the table below.

Hook Capacity (t)	Hook Weight (t)	Maximum rated loads (t)									
		11falls	10falls	9falls	8falls	7falls	6falls	5falls	4falls	3falls	2falls
150	2.35	132.0	120.0	108.0	96.0	84.0	72.0	60.0	48.0	36.0	24.0
80	1.35					80.0	72.0	60.0	48.0	36.0	24.0
35	0.90									35.0	24.0

Clamshell Specifications

Dimensions and Specifications

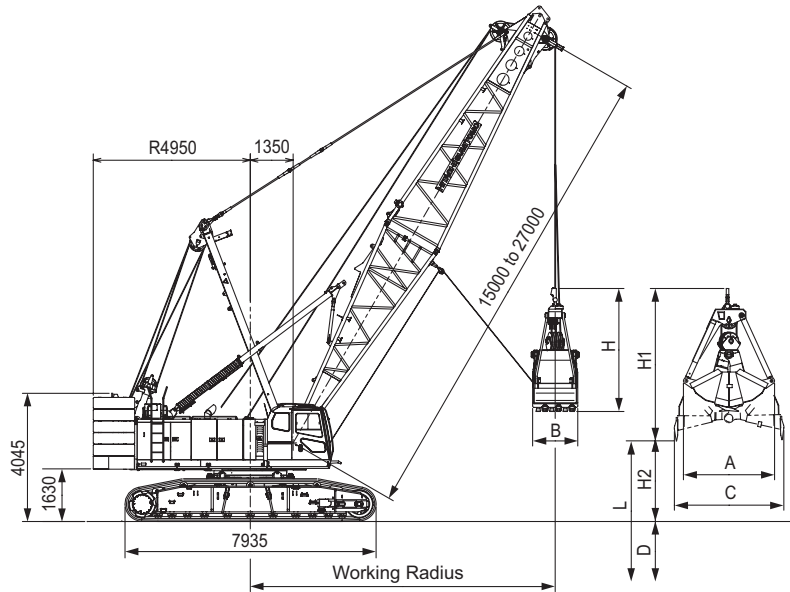

Working Ranges

Boom Length	m	15				18				21				24				27			
Boom Angle	°	35	45	55	65	35	45	55	65	35	45	55	65	35	45	55	65	35	45	55	65
Working Radius	m	14.2	12.6	10.7	8.5	16.7	14.8	12.4	9.8	19.1	16.9	14.1	11.1	21.6	19.0	15.9	12.3	24.0	21.1	17.6	13.6
Gross Rated Load	t	12.5	12.5	12.5	12.5	12.5	12.5	12.5	12.5	12.5	12.5	12.5	12.5	12.5	12.5	12.5	12.5	12.5	12.5	12.5	12.5
Lift L (D + H2)	m	39.8	41.9	43.6	45.0	41.5	43.9	46.0	47.7	43.1	46.0	48.4	50.4	44.7	48.0	50.8	53.0	46.4	50.1	53.2	55.7
Max. Digging Depth D	m	36																			
Bucket Dumping Height H2	m	3.8	5.9	7.6	9.0	5.5	7.9	10.0	11.7	7.1	10.0	12.4	14.4	8.7	12.0	14.8	17.0	10.4	14.1	17.2	19.7

Specifications

Clamshell Specifications	
Bucket Capacity	m ³ 3.0
Allowed Maximum Gross Weight for Clamshell Bucket and Captured Load Combined	t 12.5
Boom Length	m 15 to 27
Maximum Digging Depth	m 36
Support Wire Rope Speed *	m/min 64
Opening/Closing Wire Rope Speed *	m/min 64
Boom Hoist Drum Wire Rope Speed (Raise) *	m/min 44
Boom Hoist Drum Wire Rope Speed (Lower) *	m/min 44
Ground Contact Pressure	kPa (kgf/cm ²) 95.5 (0.97) (w/ Basic Boom, 3.0 m ³ Clamshell Bucket)
Overall Operating Weight	t Approximately 128.5 (w/ Basic Boom, 3.0 m ³ Clamshell Bucket)

NOTE :

- Speeds marked with "*" may vary depending on load applied.
- SI units are used for specifications. In parenthesis, conventional units are also indicated.
- Specifications other than those shown above are the same as those shown in the crane specifications section.

Clamshell Bucket

Capacity (m ³)	Weight (t)	A (mm)	B (mm)	C (mm)	H (mm)	H1 (mm)
3.0	6.5	2,980	1,650	3,500	3,550	4,550

Gross Rated Load Table

Working Radius(m)	Boom length (m)				
	15	18	21	24	27
8.5	12.5				
9.0	12.5	12.5 /9.8			
10.0	12.5	12.5	12.5 /11.1		
12.0	12.5	12.5	12.5	12.5 /12.3	12.5 /13.6
14.0	12.5	12.5	12.5	12.5	12.5
16.0	12.5 /14.2	12.5	12.5	12.5	12.5
18.0		12.5 /16.7	12.5	12.5	12.5
20.0			12.5 /19.1	12.5	12.5
22.0				12.5 /21.6	12.5
24.0					12.5

Unit: ton

1. Max. clamshell rating is 12.5 t.
2. Mass of bucket plus load should not exceed clamshell ratings shown above. Following data are for a general digging application buckets.

Bucket capacity	2.5 m ³	3.0 m ³
Bucket mass	5.5 t	6.0 t

3. In case of clamshell application, a 15.0 m boom is recommended as minimum length of boom, and max. boom length shall not exceed 27.0 m.
4. Apparent specific gravity of lifting material:
Earth1.7 to 1.8 t/m³
Gravel1.8 to 2.0 t/m³
5. Use the counterweight in an assembly configuration (49.6 t) that does not include the lower weight and top weight.
6. Max. digging depth below ground shall be 36 m.

Weights and Dimensions of Disassembled Units

Weights and Dimensions List

Weights and Dimensions of Disassembled Units

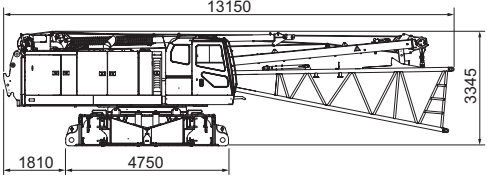
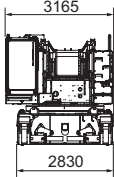
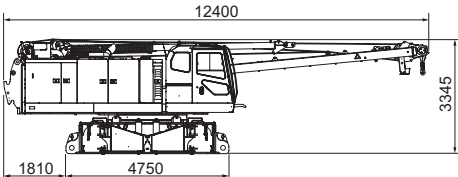
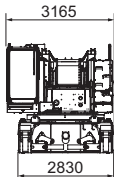
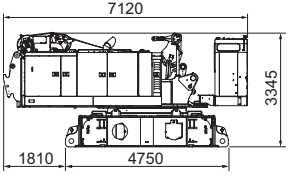
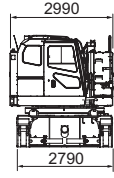
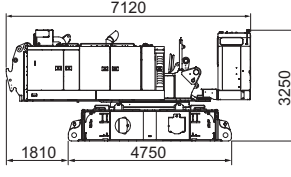
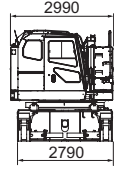
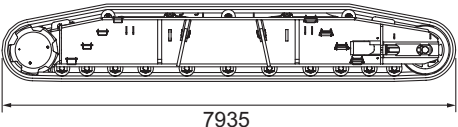
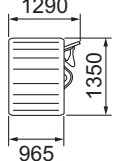
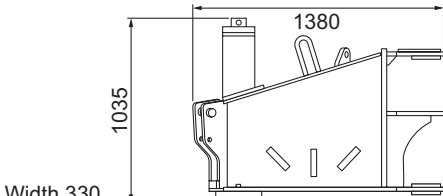
Description	Qty	Dimensions (mm)		Weight (kg)
Base Crane with: Backstops Boom Base Mast Front Winch Wire Rope Jacks Upper & Lower Spreader Floats	1			41300
Base Crane with: Backstops Mast Front Winch Wire Rope Jacks Upper & Lower Spreader Floats	1			39100
Base Crane with: Boom Hoist Winch Wire Rope Front Winch Wire Rope Upper & Lower Spreader Without: Mast Jacks Floats	1			34900
Base Crane Without: Mast Wire Rope Jacks Upper & Lower Spreader Floats	1			31800
Crawler (Assembly)	2			14200
Jack Beams	4			420

Weights and Dimensions of Disassembled Units

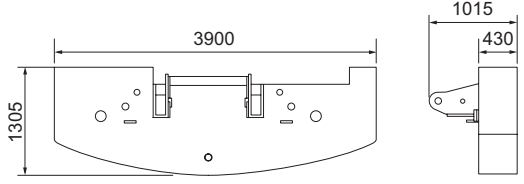
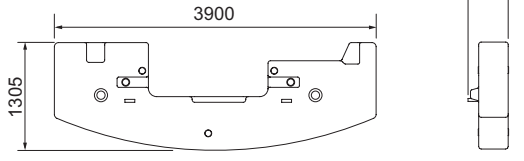
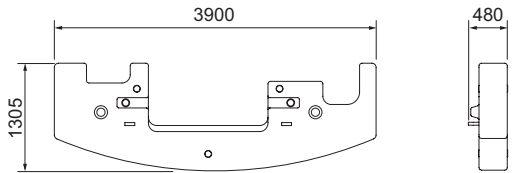
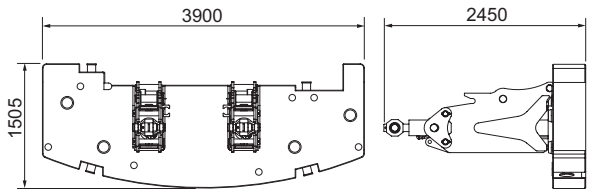
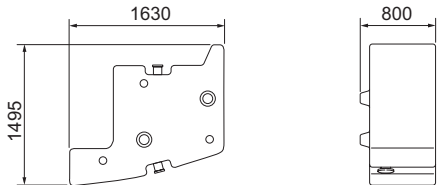
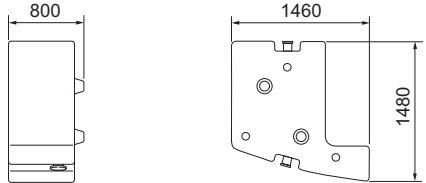
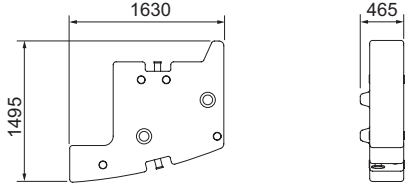
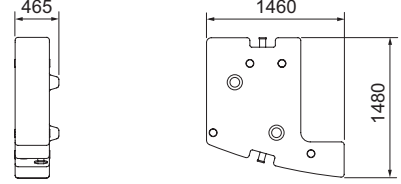
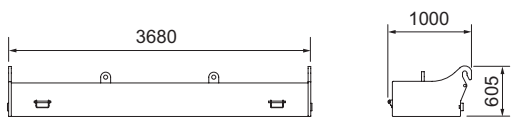
Description	Qty	Dimensions (mm)	Weight (kg)
Counterweight (Base)	1		9100
Counterweight	5		8100
Counterweight (Top Weight)	1		6860
Counterweight with Self Assembly Unit (Base)	1		9220
Counterweight (For Counterweight with Self Assembly Unit)	3		6410
Counterweight (For Counterweight with Self Assembly Unit)	3		6780
Counterweight (Top Weight) (For Counterweight with Self Assembly Unit)	1		3340
Counterweight (Top Weight) (For Counterweight with Self Assembly Unit)	1		3530
Lower Weight	2		4500

Weights and Dimensions of Disassembled Units

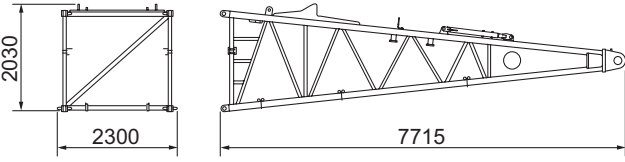
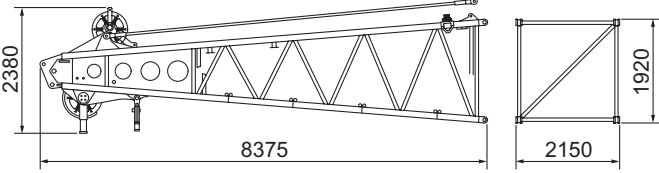
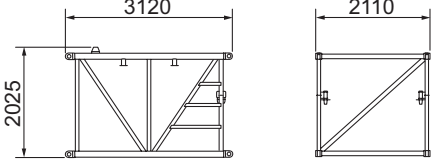
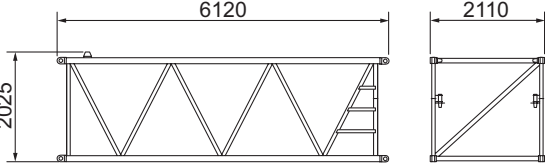
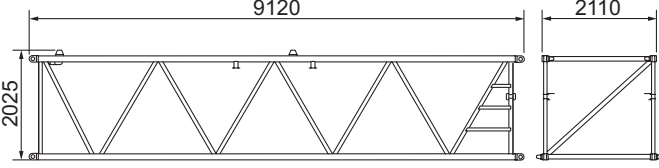
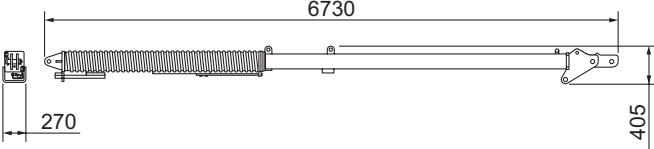
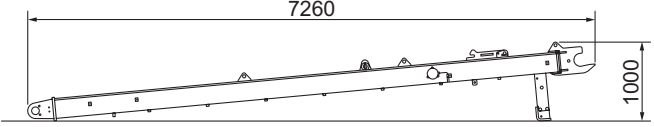
Description	Qty	Dimensions (mm)	Weight (kg)
Boom Base	1		2200
Boom Top	1		2400
3 m Boom Insert	1		470
6 m Boom Insert	1		760
9 m Boom Insert	1		1050
Boom Backstops	2		490
Mast	1	 <p>Width 1230</p>	1480

Weights and Dimensions of Disassembled Units

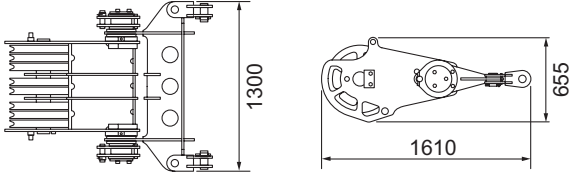
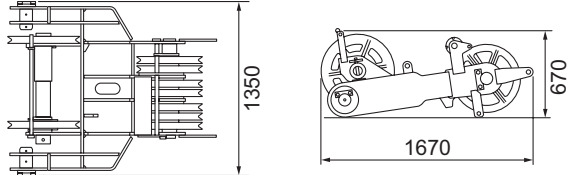
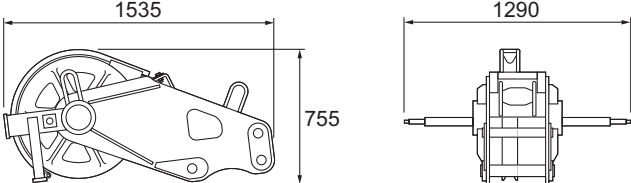
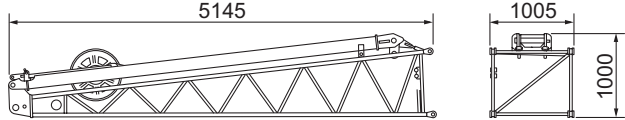
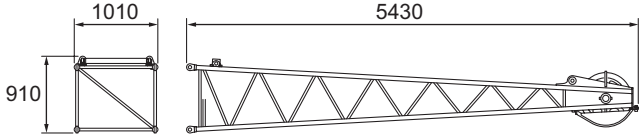
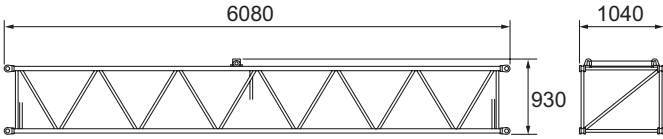
Description	Qty	Dimensions (mm)	Weight (kg)
Upper Spreader	1		810
Lower Spreader	1		870
Aux. Sheave	1		350
Jib Base (with Jib Strut)	1		580
Jib Top	1		290
6 m Jib Insert	1		190

Weights and Dimensions of Disassembled Units

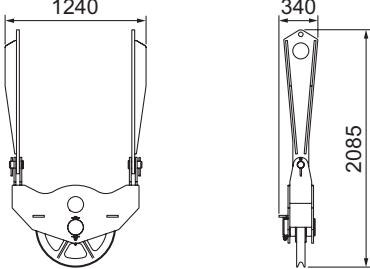
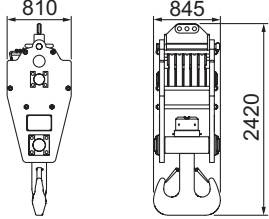
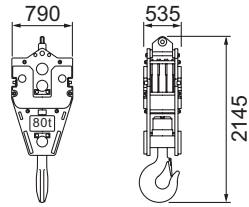
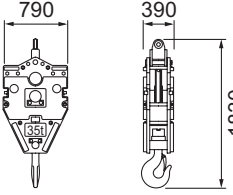
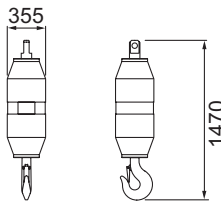
Description	Qty	Dimensions (mm)		Weight (kg)
Boom Top Side Spreader	1			370
150 t Hook	1			2350
80 t Hook	1			1350
35 t Hook	1			900
13.5 t Hook	1			620

Equipment List

Standard and Optional Equipment

○ : Standard ● : Optional — : No setting

Item		Crane	Clamshell
Lower Structure	965 mm Crawler Shoe	○	○
	Jack Up Unit	○	○
	Crawler Side Frame Connecting Unit	○	○
	Up/Down Steps	○	○
	Shoe Tension Unit (Hydraulic)	●	●
	Low Wear Shoe (Contiguous surface of roller)	●	●
Upper Structure	Cab Up/Down Catwalk	○	○
	Upper House Handrails (For catwalk)	○	○
	Under Cover (Bed lower surface)	○	○
	Working Light (× 2)	○	○
	Back Mirror (Left and right)	○	○
	Central Lubrication Unit (For turntable bearing)	○	○
	Drum Flange Cover	○	○
	Auto Idle Stop	○	○
	Eco Winch	○	○
	Drum Light (Front winch)	●	●
	Winch Rope Retainer (Front winch)	●	●
	Winch Rope Retainer (Rear winch)	●	●
	Catwalk (Folding type, Left / Right)	● / ○ ^{*4}	● / ○ ^{*4}
	Electric Fuel Pump	●	●
	Upper House Handrails (Folding type)	● / ○ ^{*4}	● / ○ ^{*4}
	Winch with Front and Rear Free Mechanism	○	○
	Third Winch (Rope not included) (with Free mechanism)	● ^{*3}	-
Short Length Bolts For 49.6t Counterweight	-	○	
Cab	Air Conditioner	○	○
	Sunvisor	○	○
	Sunshade	○	○
	Wiper with Washer (Front window, Cab roof window)	○	○
	Microphone & Loud-Speaker	●	●
	AM / FM Radio (with Clock)	○	○
	Room Lamp	○	○
	Cup Holder	○	○
	24 V Power Socket (× 2)	○	○
	Floor Carpet	○	○
	Level Gauge (in Cab & lower frame)	○	○
	Accelerator Pedal (Right side)	●	●
	Armchair Lever	○	○
	Cross Operation Lever (Lever lock not attached)	● / ○ ^{*4}	● / ○ ^{*4}
	Front Operation Lever (with Lever lock)	●	●
	Seat without Suspension	○	○
	Seat with Suspension	● / ○ ^{*4}	● / ○ ^{*4}
	Travel Operation Pedal (Cannot be installed when winch with free mechanism attached)	●	●
	Boom Hoist Operation Pedal ^{*1}	●	●
	Swing Brake Operation Pedal ^{*1}	●	●
	Fan	●	●
	Front/Rear Operation Lever, Brake Pedal Permutation	●	●
	Fuel Burning Heater	●	●
	Accelerator Grip	○	○
	Drum Rotation Sensor (Front/Rear/Boom Hoist) ^{*2}	○	○
Speed Control Dial (Front/Rear/Boom Hoist/Swing)	○	○	
Lifehammer	○	○	

*1 Cannot be installed at the same time.

*2 Cannot be equipped when the cross operation lever or front operation lever is installed.

*3 The third winch can only be used in the crane specification.

*4 Europe specification machines only.

○ : Standard ● : Optional — : No setting

Item		Crane	Clamshell	
Attachment	15 m Basic Boom (Boom base: 7.5 m, Top: 7.5 m)	○	○	
	3 m Boom Insert	●	●	
	6 m Boom Insert	●	●	
	9 m Boom Insert	●	●	
	Parts Set for 10 m crane jib [10 m Basic jib, Anti-two block, Jib mast]	●	-	
	6 m Crane Jib Insert	●	-	
	Midpoint Pendant Rope (Required when the boom length is 66 m or longer)	●	-	
	Auxiliary Sheave [including Auxiliary sheave anti-two block]	●	-	
	Boom Top Side Spreader	●	-	
	150 t Hook (5 sheaves)	●	-	
	80 t Hook (3 sheaves)	●	-	
	35 t Hook (1 sheave)	●	-	
	13.5 t Hook	●	-	
Front Winch (φ 28)	P · S (19) + 39XP · 7	○	-	
		-	○ ^{*6}	
	Rear Winch (φ 28)	Mono Rope EP 3XF (40)	●	-
		P · S (19) + 39XP · 7	●	-
	Third Winch (φ 26)	IWRC 6 X P · WS (31)	●	○ ^{*7}
P · S (19) + 39XP · 7		●	-	
Boom Hoist Winch (φ 22.4)	IWRC 6 X P · WS (31)	○	○	
Safety Device	Moment Limiter	○	○	
	3 Color Percentage Indicator	●	●	
	Gate Lock Lever	○	○	
	Individual Winch Operation Lever Lock (Front, Rear, Hoist, Travel) ^{*5}	○	○	
	Automatic Drum Lock (Boom Hoist)	○	○	
	Winch Drum Lock (Front/Rear)	○	○	
	Winch Drum Dead Turns Detective Device	● / ○ ^{*8}	● / ○ ^{*8}	
	Swing Lock	○	○	
	Swing Alarm	○	○	
	Travel Alarm	○	○	
	Auto Slowdown (Slow stop)	○	○	
	Boom Hoist Limiting Device	○	○	
	Secondary Boom Over Hoist Prevent Device	○	○	
	Warning Alarm	○	○	
	Monitor Panel (Machine monitoring)	○	○	
	Engine Start Interlock System	○	○	
	Emergency Engine Stop Switch (In cab)	○	○	
	Lifting Height Indication Device	○	○	
	Anti-Two Block	○	-	
	Moment Limiter (M/L) Mode Selector (In left house)	● / ○ ^{*8}	○	
	Swing Restriction Unit	●	●	
	Lowering Limiter	● / ○ ^{*8}	● / ○ ^{*8}	
	Anemometer	●	-	
Obstacle Lights (Fixed lights)	●	-		
Drum and Rear View Monitor System (3 cameras)	●	●		
Cab Roof Window Guard	● / ○ ^{*8}	● / ○ ^{*8}		

*5 An operation lever lock is not attached to the front, rear or hoist when the cross operation lever is installed.

*6 Used for opening/closing rope. 82m length rope required for 12m diggind depth with 21m boom length.

*7 Used for supporting rope. 70m length rope required for 12m diggind depth with 21m boom length.

*8 Europe specification machines only.

○ : Standard ● : Optional — : No setting

Item		Crane	Clamshell	
Common parts	Boom Foot Pin Removal / Installation Cylinder	●	●	
	Boom Back Stop	○	○	
	Boom Angle Sensor	○	○	
	Boom Lifting Piece	○	○	
	Remote Sensing (Mobile Communication Terminal and Data Logging Device)	○	○	
	Remote Sensing (Satellite Communication Terminal and Data Logging Device)	●	●	
	Assembly Pad ^{*9}	●	-	
	Quick Draw for Side Frame Self Assembly ^{*10}	●	●	
	Counterweight with Self Assembly Unit	●	●	
	Skywalk (with Stanchion)	●	-	
	Skywalk (without Stanchion)	●	-	
	Boom Top Under Surface Buffer (Protector)	●	●	
	Load Table Sign (Whiteboard, boom base installation)	●	●	
	Insertable Company Name Plate (Both side surfaces of the machine)	● ^{*13}	●	
	Opening / Closing / Support Rope Stopper	-	○	
	Hyd. Tagline (6 × Fi (29) φ 10 mm × 55 m)	● ^{*11}	○	
	Reeving Winch (4 × F (30) φ 8 mm × 250 m)	● ^{*11}	-	
	Reeving Winch cum Hydraulic tagline	For hydraulic tagline (6 × Fi (29) φ 10 mm × 55 m) For reeving (6 × Fi (29) φ 10 mm × 220 m)	● ^{*11}	-
	Reduction Counterweight Specification	● ^{*12}	-	
	Sling Ropes for Disassembly and Assembly (For counterweights, Crawlers)	●	●	
Air Cleaner Double Element	○	○		
Additional Fuel Filter (Triple filter)	●	●		
Additional Spare Parts (Hydraulic oil filter)	●	●		
Additional Tools (Large hammer, Crowbar, Chisel)	●	●		
Other	Standard Supplied Tools	○	○	
	Standard Spare Parts	○	○	

*9 The assembly pad is required for the following attachments.

- Crane Boom Longest Length 75m
- Crane Boom Length 72m + Aux. Sheave
- Crane Boom Length 63m + Crane Jib

*10 When using the reeving winch or hydraulic tagline, remove the side frame self assembly quick draw.

*11 (1) Hydraulic tagline (maximum line pull: 2.9 kN (300 kg))

(2) Reeving winch unit (maximum line pull: 11.8 ZkN (1,200 kg))

(3) Reeving winch and hydraulic tagline

(Line pull: For hydraulic tagline (maximum line pull: 1.5 kN (150 kg)) /for reeving winch (maximum line pull: 2.9 kN (300 kg))

*12 The reduction counterweight specification can only be used for the crane specification, with the exception of the crane jib.

*13 When it choose, the width at the time of transportation is set to not less than 3m.

- We are constantly improving our products and therefore reserve the right to change designs and specifications without notice.
- Units in this specification are shown under International System of Units; the figures in parenthesis are under Gravitational System of Units as old one.

Hitachi Sumitomo Heavy Industries Construction Crane Co.,Ltd.

9-3, Higashi-Ueno 6-chome, Taito-ku, Tokyo 110-0015, Japan
Phone: 81-3-3845-1387 Facsimile: 81-3-3845-1394

<http://www.hsc-crane.com>